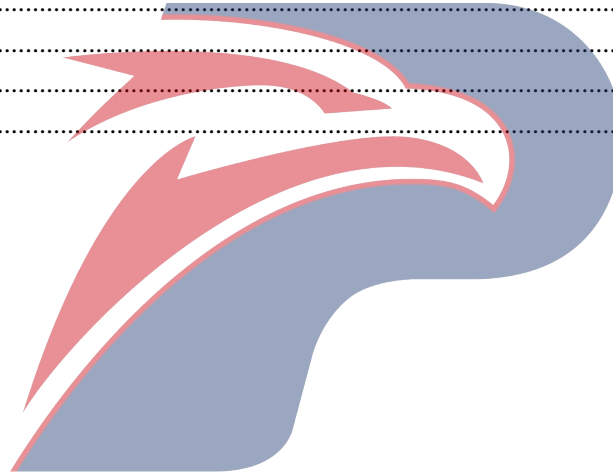




**1 IMPORTANT INFORMATION**

Vehicle identification number (VIN) and engine number .....	1-2
Overloading .....	1-4
Operation of new vehicle.....	1-4
Operation and care of vehicle.....	1-6
Maintenance .....	1-6
Do not coast in neutral position.....	1-6

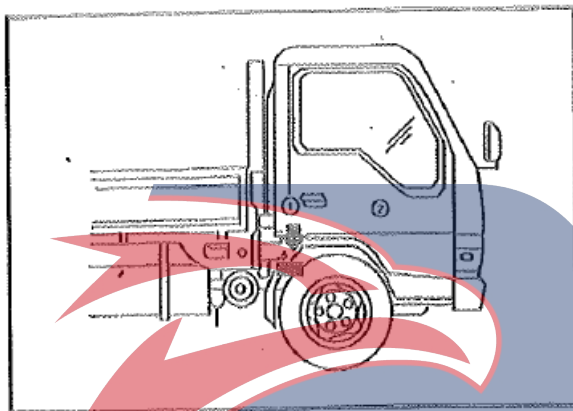


**POWER STAR**



## IMPORTANT INFORMATION

The following information is important for the proper care and economical operation of your Isuzu vehicle and should be thoroughly understood before putting it into service.

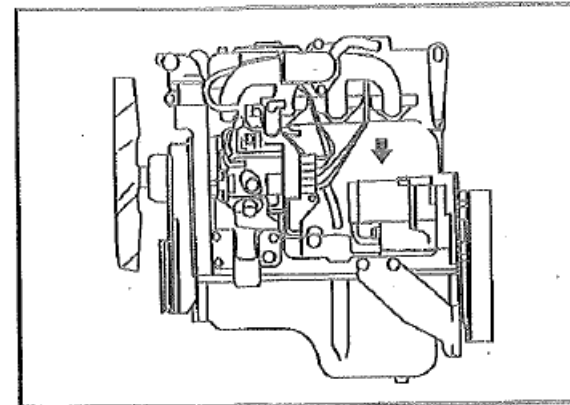


### Vehicle Identification Number (VIN) and Engine Numbers

Please note the vehicle identification number and engine number, which is necessary document for you to contact the QingLing Motors Special Distribution Store (Maintenance Station).

#### VIN:

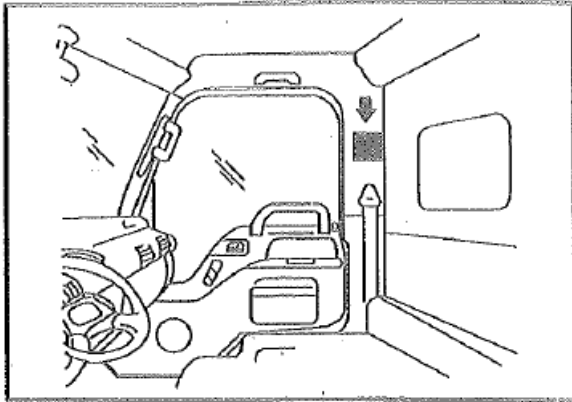
The VIN is stamped on the right-side front part of the frame.



### Engine number:

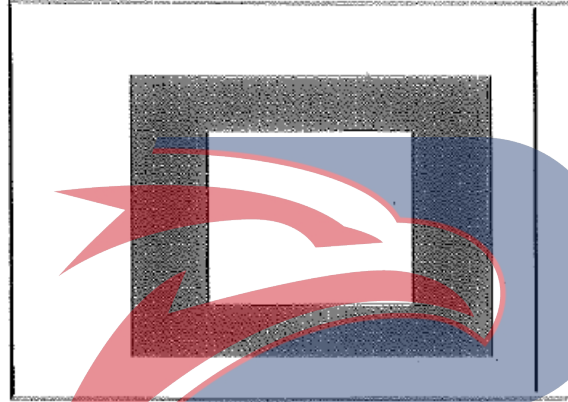
The engine number is stamped on the lower center left hand side of the cylinder block.

# POWERSTAR



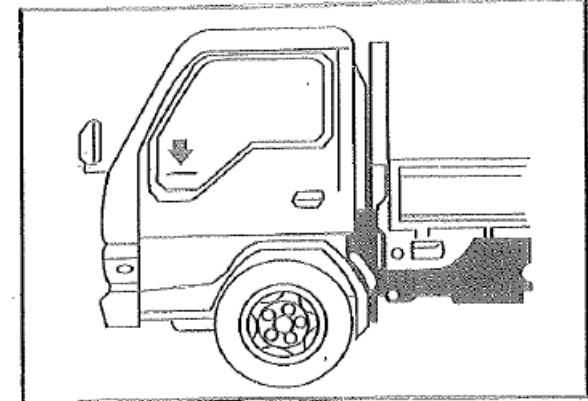
**Vehicle nameplate:**

The single-row seat vehicle nameplate is mounted on the inside of the body side panel next to the side seat of the assistant.



**Vehicle nameplate:**

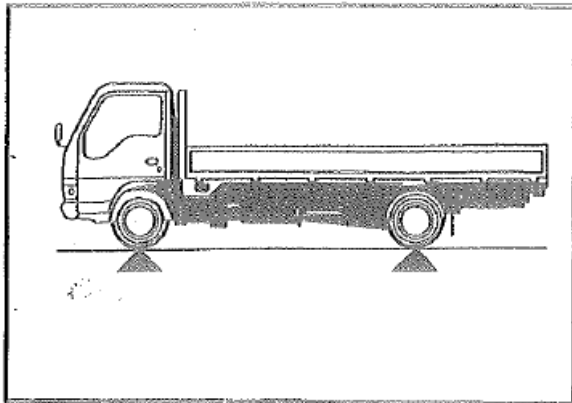
The nameplate for the double row seat is mounted on the inside of the body side board on the right side of the rear seat.



**Vehicle identification plate:**

The vehicle identification plate is mounted on the left end of the instrument panel.

# POWERSTAR



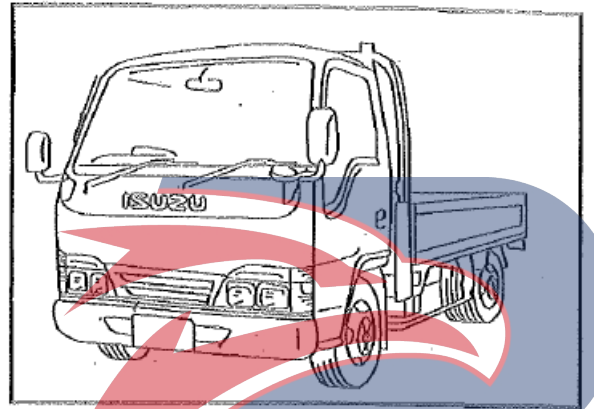
## OVERLOADING

### **WARNING**

Overloading not only shortens the service life of your vehicle, but also causes serious potential safety hazards.

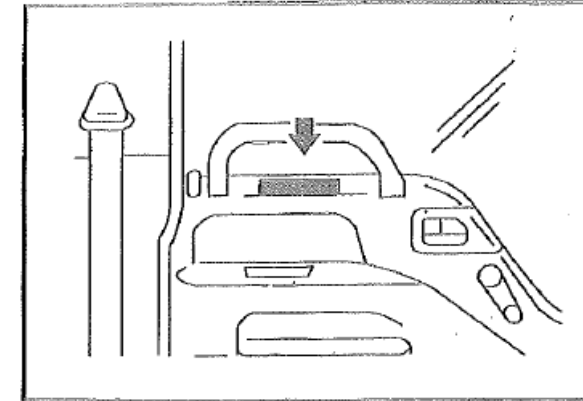
The weight of the payload must be limited within the GVM (Gross Vehicle Mass) rating and distributed over the front and rear axles so as not to exceed their axle capacities.

Refer to "MAIN DATA AND SPECIFICATIONS" for GVM and Axle capacity for each model.



## OPERATION OF NEW VEHICLE

It is important to observe the following precautions as the treatment and care that your vehicle will receive during the break-in period have a strong influence over the performance and service life of the vehicle. Therefore, during the running-in of 1000 km of initial driving, the following attention shall be strictly observed:



1. Within 1000 km of initial driving, speed and rotating speed shall be controlled according to the following requirements.

### **Press the vehicle speed:**

The running speed of the vehicle shall be 10 km less than the specified speed.

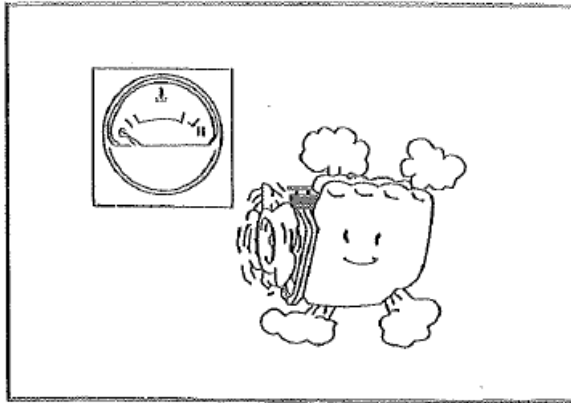
### **According to rotating speed:**

Limited engine speed:

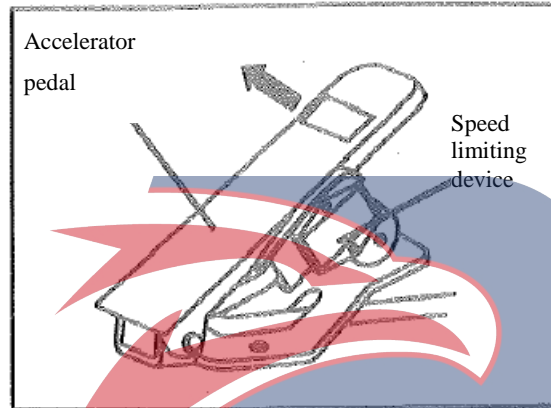
Less than 2800 rpm

### **WARNING**

It is forbidden to use inferior fuel. The inferior fuel will cause blockage of the engine oil supply system and affect the normal use of the vehicle.

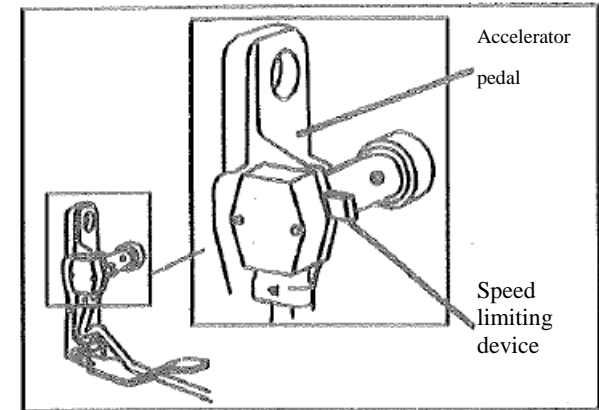


2. Avoid engine racing, abrupt starting and needless hard stops.
3. Always let the engine idle until it becomes thoroughly warmed up.



### Speed Limiting device

In order to achieve a good break-in effect, extend the service life of the vehicle. For some models, the speed limit device is provided at the factory to avoid the engine overspeed running and suddenly starting the vehicle.



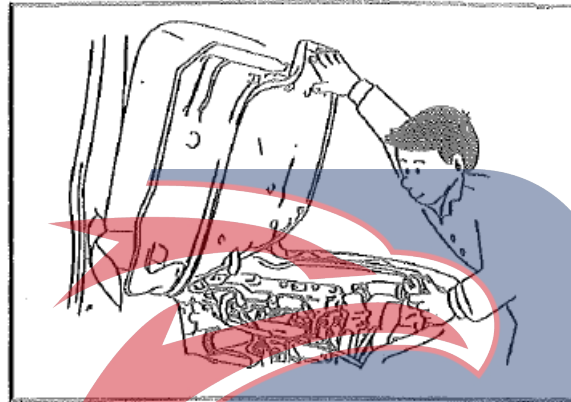
The speed limiting device is mounted under the accelerator pedal, and if the accelerator pedal is raised up and the accelerator pedal can be seen.

# POWERSTAR



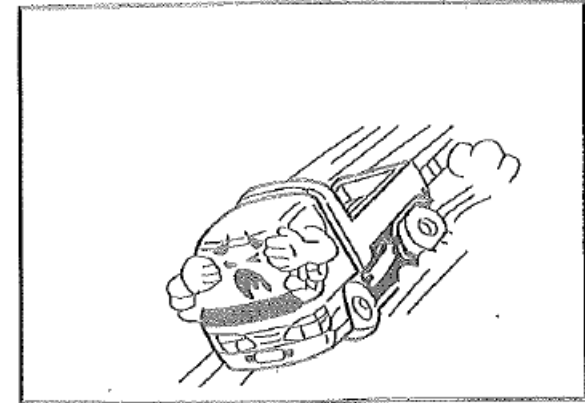
## OPERATION AND CARE OF VEHICLE

Every component and system of your vehicle should be checked according to "CONTROLS AND INSTRUMENTS" and "DRIVING" sections.



### MAINTENANCE

In order to maintain safe and dependable vehicle operation, inspection and adjustment should be performed as outlined in "SERVICE AND MAINTENANCE". Your authorized dealer is willing to perform regular maintenance checks on your vehicle.



### DO NOT COAST IN NEUTRAL POSITION

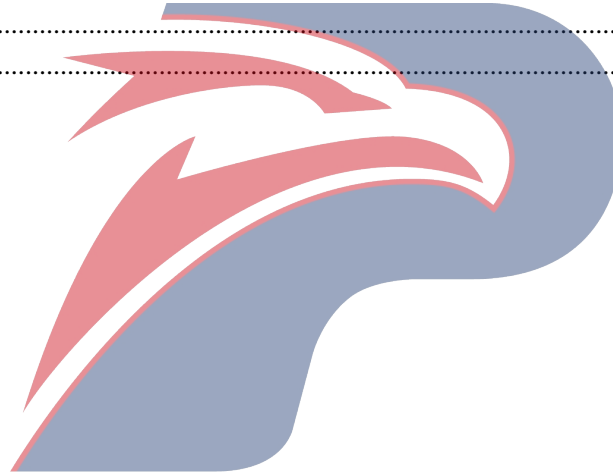
During driving, it is strictly prohibited to coast in Neutral position. Otherwise, it is easy to cause engine, vehicle fault and driving safety.

# POWERSTAR



## **2** CONTROLS AND INSTRUMENTS

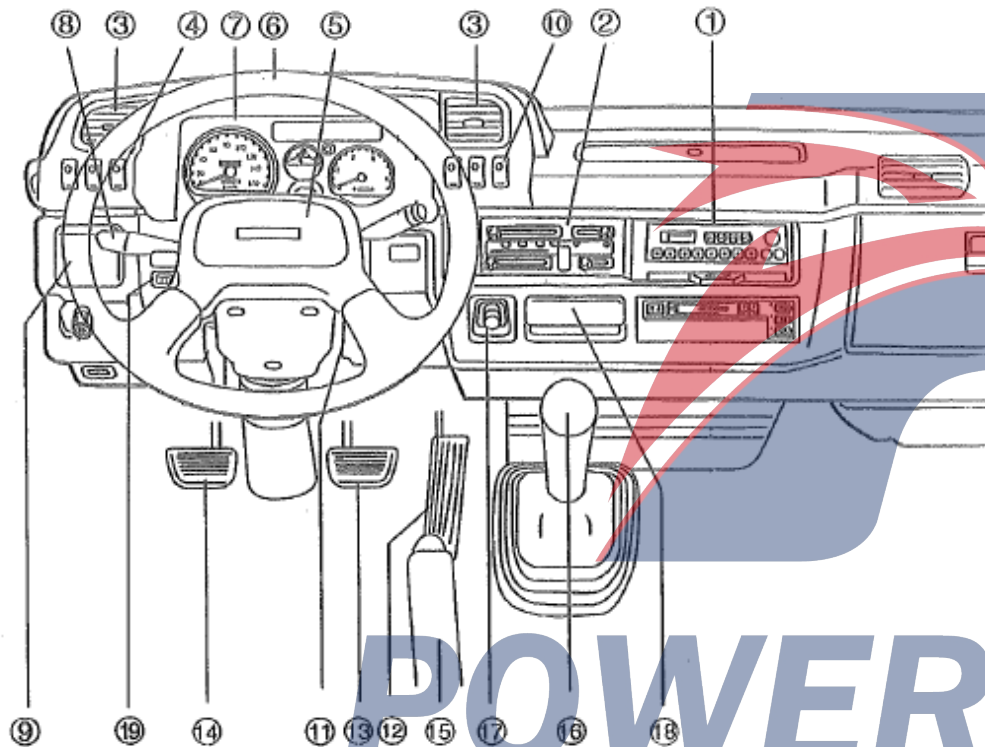
Meters and indicator lamps .....	2-3
Steering column controls .....	2-9
Instrument cluster .....	2-14
Floor controls .....	2-16
Others .....	2-17



# **POWERSTAR**



## CONTROLS AND INSTRUMENTS



- ④ Front fog lamp switch
- ⑤ Horn button
- ⑥ Steering wheel
- ⑦ Instrument and indicator panel
- ⑧ Combined switch handle
- ⑨ Ashtray (driver's side)
- ⑩ Hazard Warning lamp switch
- ⑪ Starter switch
- ⑫ Accelerator pedal
- ⑬ Brake pedal
- ⑭ Clutch pedal
- ⑮ Parking brake lever
- ⑯ Shift Lever
- ⑰ Cigarette lighter
- ⑱ Ashtray (assistant side)
- ⑲ Switch-headlight adjustment

① Radio

② Heating device, defroster control panel

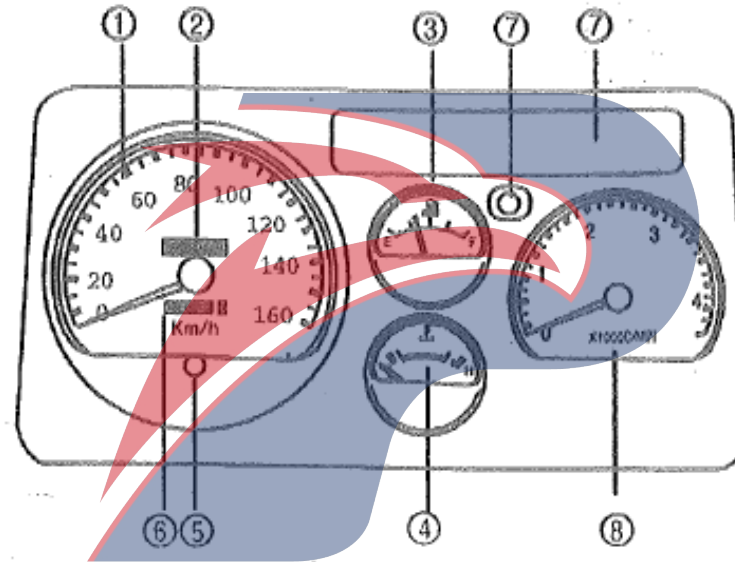
③ Dashboard vent grille





## Meters and indicator lamps

### Dashboard



① Speedometer

② Tachograph

③ Fuel gauge

④ Engine coolant temperature gau

⑤ Reset knob

⑥ Trip counter

⑦ Indicator and warning lamp panel

⑧ Engine tachometer

POWERSTAR



## Indicator/Warning lamps



Turn signal indicator lamp



High beam indicator lamp



Generator indicator lamp



Parking and brake fluid level indicator



Indicator for preheating



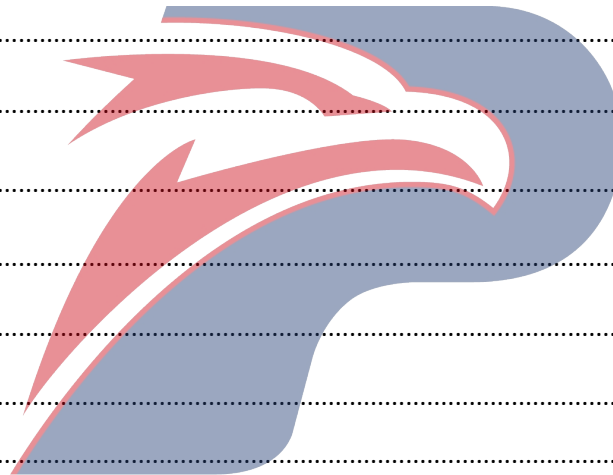
Oil pressure indicator lamp



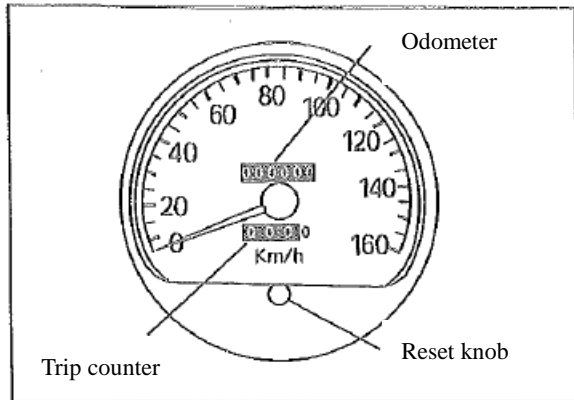
Water-in-fuel filter indicator lamp



Hazard warning indicator lamp



# POWERSTAR



### **Speedometer**

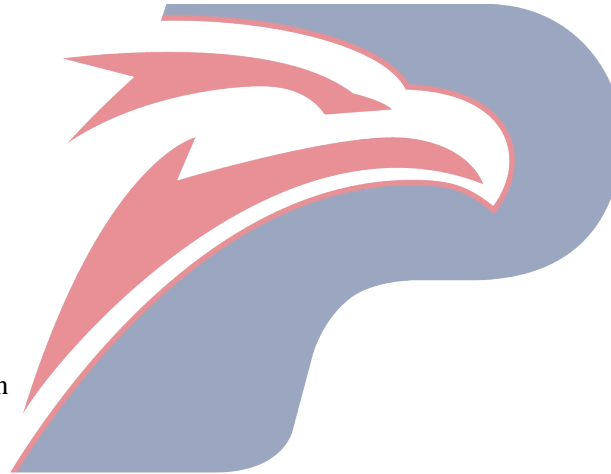
The speedometer indicates the vehicle speed in kilometers per hour (km/h) or miles per hour (mph).

### **Odometer**

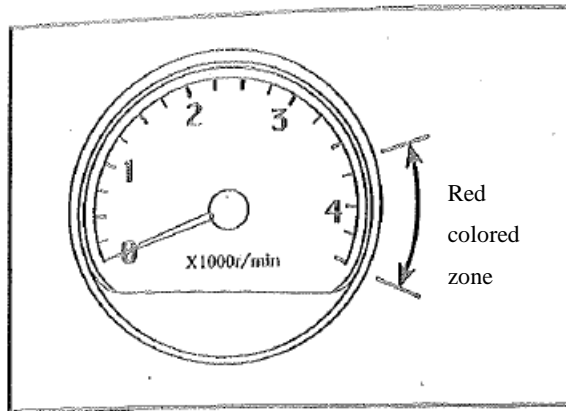
The odometer registers the accumulated distance in kilometers (or miles).

### **Trip counter and reset knob**

A reset knob for trip distance is located in speedometer lower center section. The white figures on the extreme right indicate 0.1 kilometer (or 0.1 mile). To reset trip counter, push the knob in.



# POWER STAR

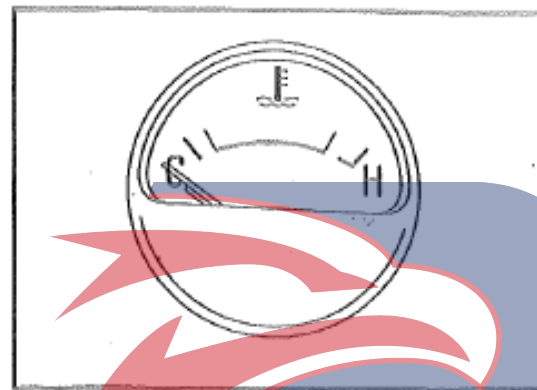


### Engine tachometer

The tachometer indicates the engine speed in revolutions per minute (rpm) and red colored zone represents critical engine speed.

#### CAUTION

Never operate the vehicle with the tachometer needle in the red zone. Continued operation with the tachometer needle in the red zone can lead to serious engine damage.



### Temperature gauge

When the start switch is turned to the "ON" position, the water temperature will indicate the temperature of the engine cooling water.

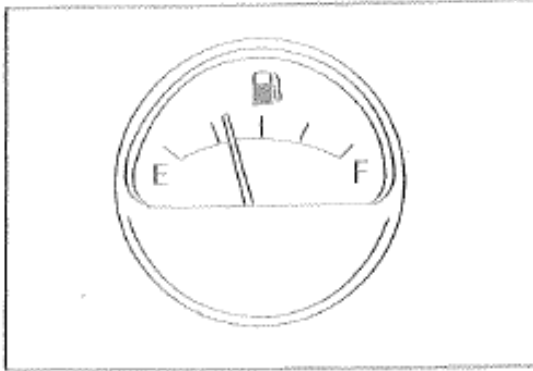
The letters " C "and" H "on the dial indicate " low temperature "and" high temperature "respectively. The cooling water temperature is normal if the water pointer is in the water tank.

#### CAUTION

• If the needle of the meter is in the red line area, it indicates that the engine is in an overheated state.

The title of "Engine Overheating" in Chapter 4 of this manual gives the operating procedures for the driver to safely park and follow.

- Continuously operating of the engine under overheated condition may cause serious damage to the engine.

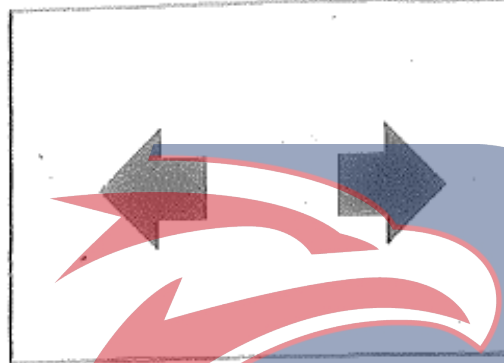


### Fuel gauge

The gauge indicates level of fuel in the fuel tank. When the start switch is turned to the "LOCK" position, the pointer does not return to the mark "E" (empty) but remains indicating approximately the fuel level in the fuel tank. The letters "F" and "E" represent "Full" and "Empty" respectively.

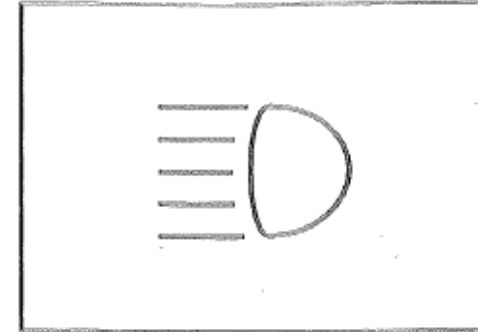
### CAUTION

It is required to develop the habit of filling the fuel in time, take care not to run the vehicle without fuel.



### Turn signal indicator lamps

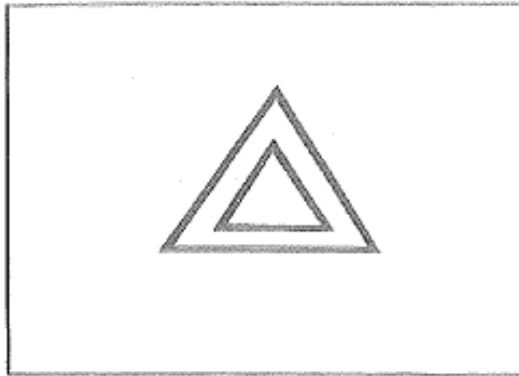
When the turn signal switch or hazard warning flasher switch is turned on, the lamp flashes to indicate operation of the external turn signal or hazard warning flasher.



### High beam indicator lamp

The indicator lamp comes on when the headlight high beams are in use.

# POWERSTAR

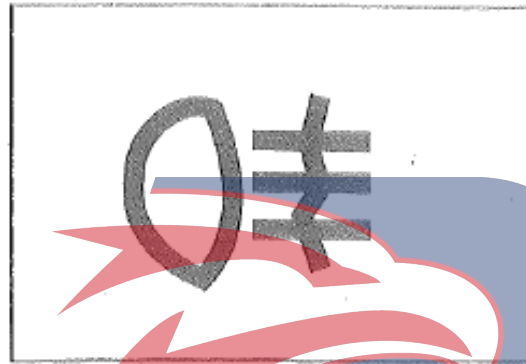


#### **Hazard warning indicator lamp**

The indicator flashes when the hazard warning flasher switch is turned on, indicating that the hazard warning flasher is working.

#### **WARNING**

- **Regardless day or night, when your vehicle becomes a traffic hazard, use a warning flasher to warn other drivers.**
- **Try to avoid parking the vehicle on the road.**



#### **Indicator lamp for rear fog lamp**

The indicator illuminates when the rear fog lamp switch is turned on, indicating that the rear fog lamp is working.



#### **Parking brake indicator and brake fluid level indicator**

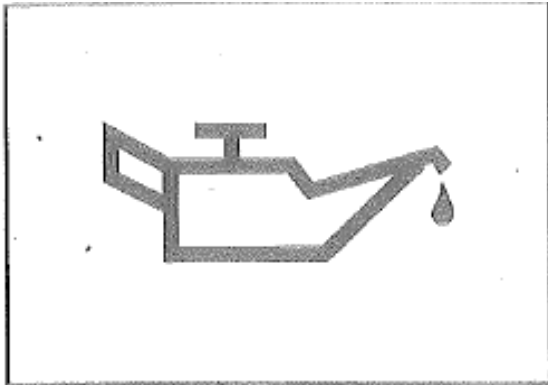
The parking brake indicator is illuminated when the start switch is in the ON position and the parking brake lever is pulled up.

The brake fluid level indicator illuminates when the fluid level in the brake fluid tank drops below the specified position.

The indicator is illuminated when the start switch is turned to the "ON" position; it is normally off when the engine is started.

If the indicator lamps on when the vehicle is running, stop and check the level of the fluid level in the brake fluid tank. If the fluid level is too low, repair it.

**POWERSTAR**



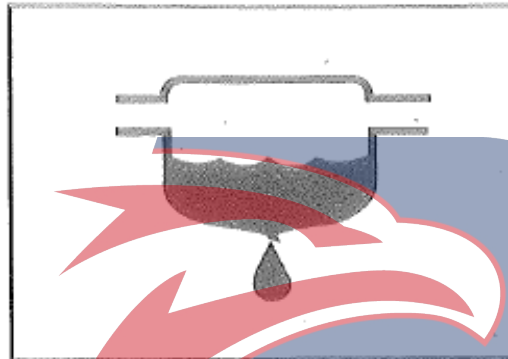
#### **Oil pressure indicator lamp**

When the start switch is turned to the "ON" position, the oil pressure indicator is illuminated; the oil pressure indicator is off when the engine is started.

#### **CAUTION**

**If the oil pressure indicator is illuminated when the vehicle is running, showing that the oil pressure is low and the engine must be shut down immediately and the engine oil level must be checked.**

**If the oil level is normal, please check the vehicle's lubrication system at the nearby QingLing Special Distribution Shop (maintenance station). Do not continue to run the engine while the indicator is on.**



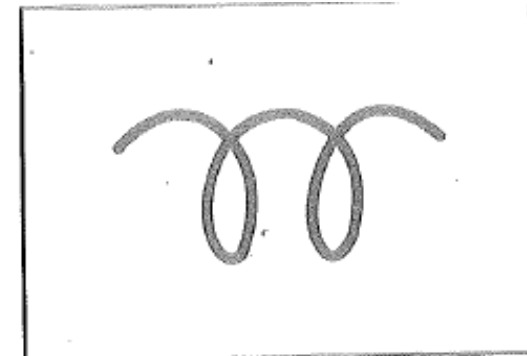
#### **Water-in-fuel filter indicator lamp**

This indicator illuminates when the water level in the water separator is higher than the specified height.

This indicator illuminates when the start switch is turned to the "ON" position; the indicator is normally off after the engine is started.

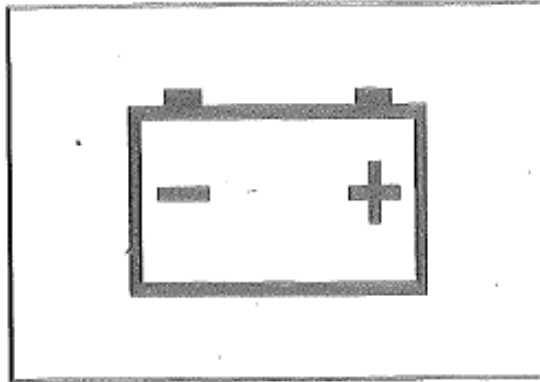
#### **NOTE**

**If the indicator is illuminated when the vehicle is running, stop and drain immediately (see the chapter "Driving").**



#### **Indicator for preheating**

When the start switch is turned to the "ON" position, the warm-up indicator lamps up; when the glow plugs are fully heated, the indicator turns off.



### Generator indicator lamp

The indicator lamp comes on when the starter switch is turned to the "ON" position and goes off when the engine is started and the generator circuit is brought into normal function.

#### NOTE

When the vehicle is running, if the generator indicator is illuminated, check the generator circuit to your nearest QingLing Maintenance Station.

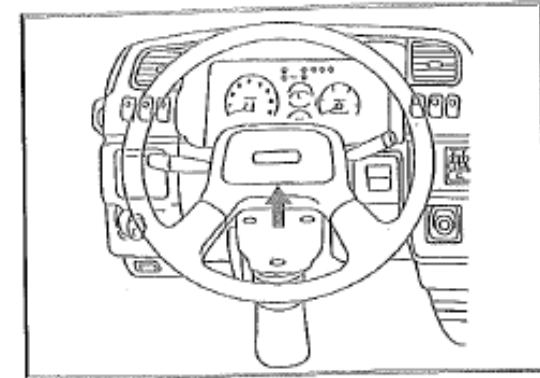
### Vacuum pressure warning peak value

This buzzer begins to sound when the pressure in the vacuum reservoir is insufficient and the brake does not work adequately.

Stop in a safe place and run the engine at a medium speed to increase the vacuum pressure.

#### CAUTION

When the buzzer sounds, the brakes cannot operate adequately, and the vehicle should not be driven.



### Steering column control

#### Steering wheel and horn button

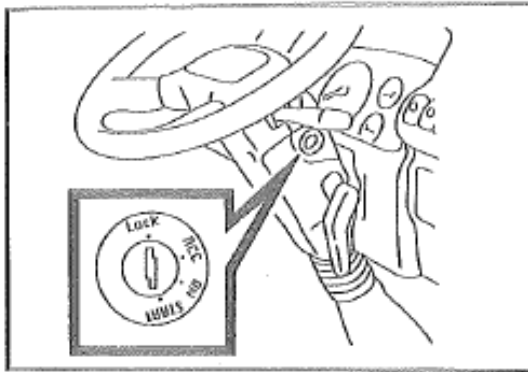
Press the horn button on the steering wheel and the horn will sound.

#### CAUTION

The steering wheel shall not be turned while the vehicle is stopped. Do not move the vehicle after the steering wheel is locked, otherwise the steering mechanism will be damaged.

POWERSTAR





### Starter switch

The switch has four changeover positions as shown in the Fig.

"LOCK": Only when the switch is in this position, the key can be inserted or removed. The steering wheel is locked when the key is removed.

### **WARNING**

Never screw the key to the "LOCK" position during driving, otherwise the steering wheel will be locked to cause a maximum risk.

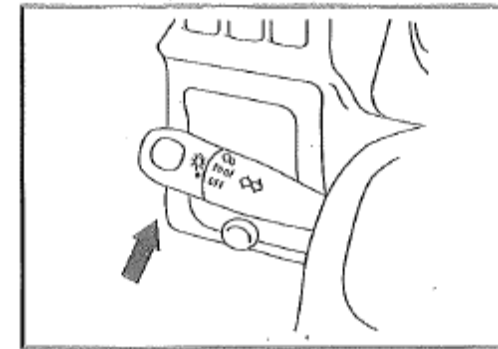
"ACC" (accessories): When the key is placed in this position, even if the engine is not running, the accessory circuit can be powered up for use.

"ON": This position is used for warm-up and normal operation.

"START": Turn the key to this position and the engine will start. As long as it goes, the key will return to the "ON" position.

### **CAUTION**

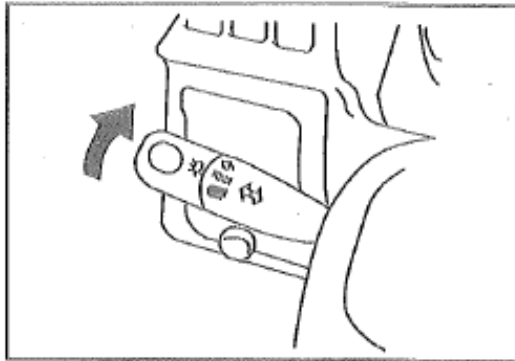
Do not operate the starter for more than 10 seconds.



### Combination switch handle

The combination switch handle controls the turn signal switch, lamp switch, dimmer switch, passing lamp switch and front fog lamp switch.

# POWERSTAR



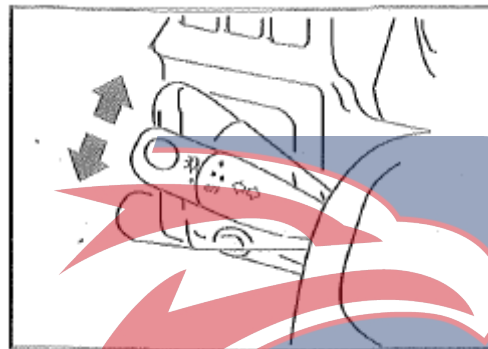
#### **Lamp control switch**

Turn the lamp control switch (top of the handle) in the three-gear to control the following lamps:

1st gear: side marker lamp, tail lamp, license lamp and instrument panel lamp

2nd gear: the above-mentioned lamps and headlight

3rd gear: the above lamps and the fog lamps

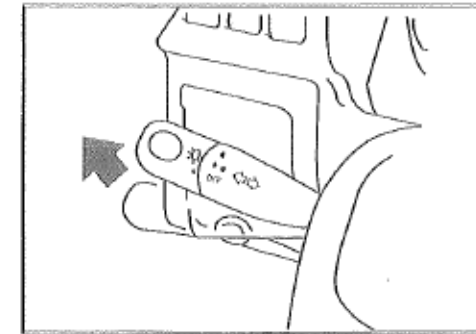


#### **Turn signal switch**

Move this combination switch lever in the direction of the turn being made so that the external turn signal lamps operate causing the turn signal indicator lamp on the instrument panel to flash. The switch lever returns automatically to the neutral position when the steering wheel is returned to the straight-ahead position.

#### **Corner lamp switch**

If the headlight is turned on, turn the turn switch and the same side corner lamp will illuminate to illuminate the area where the vehicle is turning.



#### **Headlight beam switch**

When the switch handle is pulled up, the headlight beam is converted from the upper beam to the lower beam or from the lower beam to the upper beam alternately.

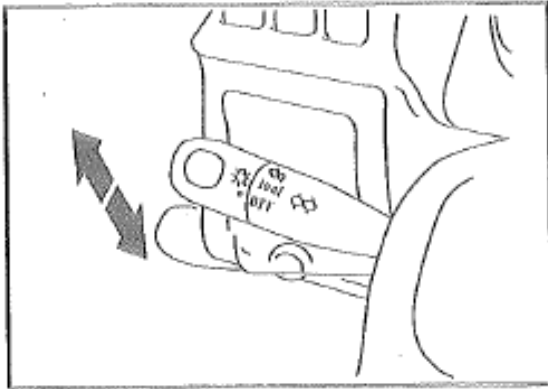
The headlight high beam indicator on the instrument panel lamps up when the headlights are on high beam.

#### **Headlight regulating switch**

When the vehicle is not loaded, the switch should be set in the "0" position.

If the beam-focusing of headlight is upward due to the loading to the vehicle, you can use the adjustable switch to reduce the angle of beam-focusing of headlight.

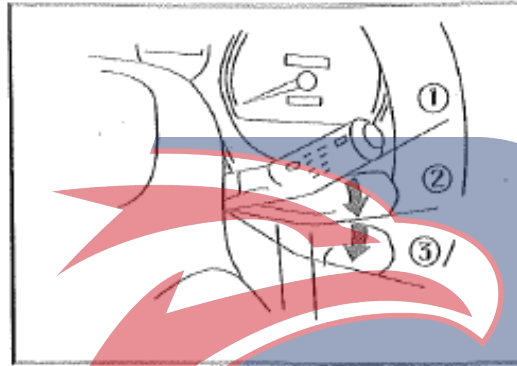
POWERSTAR



### Overtaking lamp switch

When the lamp control switch (top of the handle) is placed in the "OFF" position or in 1st gear, whenever the switch handle is raised and returned to the original position, the headlight and high beam can illuminate intermittently

To give a signal of overtaking, operate the lever repeatedly so that the lamp flashes in the daytime and at night the high and low beams come on alternately.



### Windshield wiper switch

The windshield wiper switch has three or four changeover positions for the wiper.

- ① Open ② Low speed
- ③ High speed

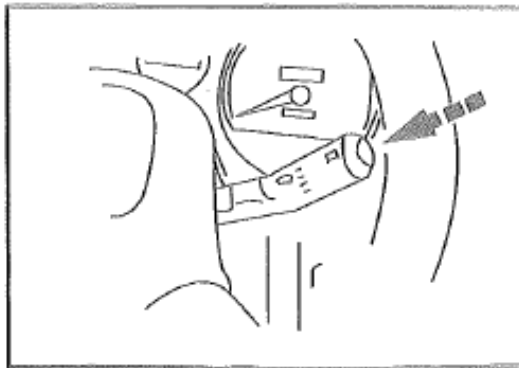
### CAUTION

Do not start the wipers when the windscreen is dry in order to avoid scratching the glass. Remove ice and snow on the wiper blade before using the wiper, and carefully loosen it and remove it if ice and snow are frozen.

### WARNING

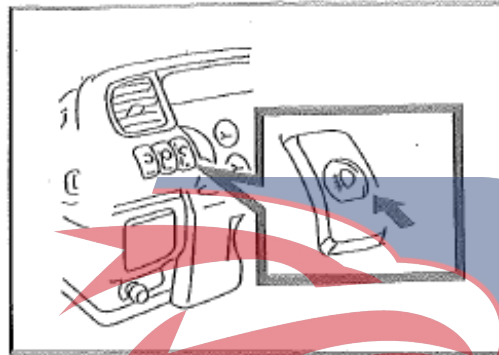
In the cold season, use the defroster to heat the windscreen before using the scrubber. This will be conducive to preventing freezing of the driver's vision.

POWER STAR



#### **Windshield washer switch**

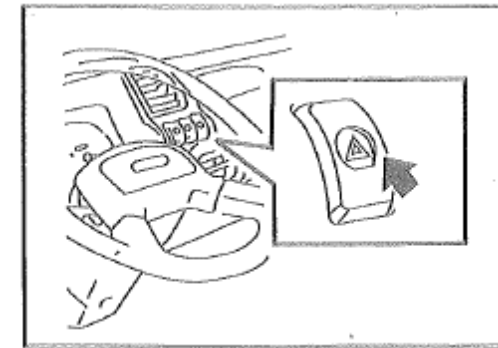
Push the button on the top of the switch in order to hold it in this position, so that the washer fluid can spray the windscreen.



#### **INSTRUMENT CLUSTER**

##### **Front anti-fog lamp switch**

When the fog affects your front view, press this switch to turn on the anti-fog lamp. Only when the headlight is in the lower beam state, the anti-fog lamp acts. The indicator lamp of the switch is on when the current anti-fog lamp is on; this switch is turned off when the fog lamp is pressed again.



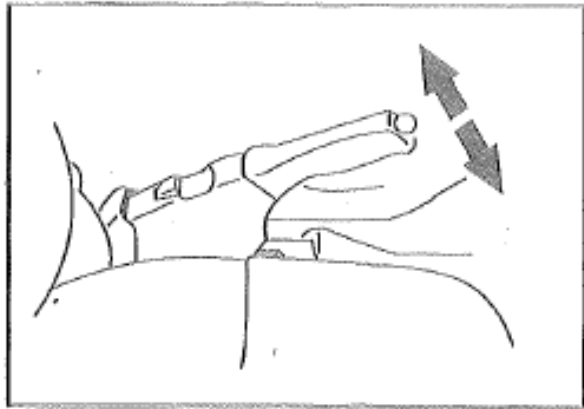
##### **Hazard warning lamp switch**

When the switch lever is raised, all the turn signal lamps are made to flash regardless of the turn signal switch position. To turn off the flasher, raise the switch lever again.

#### **CAUTION**

- **Regardless of day or night, when your vehicle becomes a traffic hazard, use a warning flasher to warn other drivers.**
- **Try to avoid parking the vehicle on the road.**

# POWERSTAR



### Parking brake lever

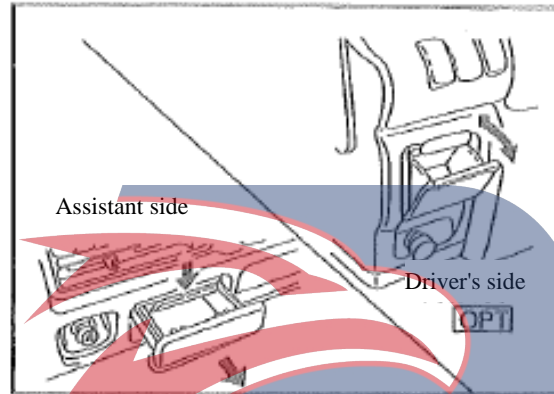
To set the parking brake, pull up the lever. To release, pull up the lever slamply and push it down fully with the button depressed at end of lever. If the park brake is not fully released when the start switch is turned to the "ON" position, the brake system indicator will illuminate.

#### **WARNING**

The indicator is independent of the performance of the parking brake

When parking brake is used, always pull the parking brake lever as far as possible.

If the parking brake does not work properly, the vehicle will slide down on a slope.

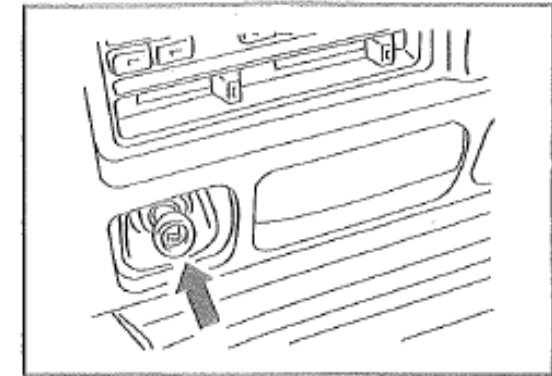


### Ashtray

To use, pull the ashtray out of the outside. To clean, while pressing the spring plate for positioning, and pull out the ashtray outward to take it out.

#### **WARNING**

After using the ashtray, close the lid completely. If not, the flame of the cigarette may cause other cigarette butts to burn, resulting in a fire.



### Cigarette lighter

When using the cigarette lighter, press the cigarette lighter inward in the "ACC" or "ON" position, and then release it.

The lighter will spring back to its normal position within about 15 seconds after pushed in and when it is ready for use. Pull the lighter out and use it.

# POWER STAR



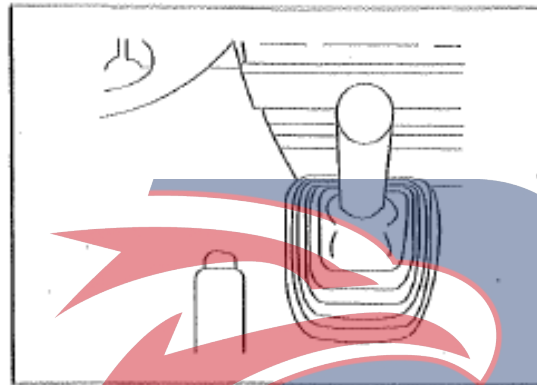
**WARNING**

Do not hold the lighter in pushed position by hand. The lighter will overheat and a fire may result. Never leave the vehicle with the lighter is pushed in. Unexpected fire may occur if it is overheated.

**NOTE**

If the lighter does not spring back after 18 seconds, it is in fault and must be pulled out in this normal position by hand.

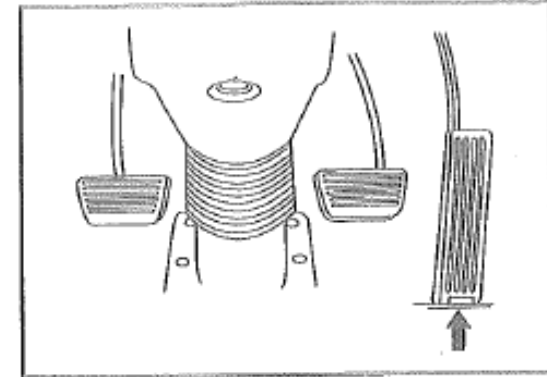
Deformed lighter will not spring back properly. Always replace it with a new QingLing genuine cigarette lighter.



**FLOOR CONTROLS**

**Shift lever**

Whenever you shift the gears, press the clutch pedal in advance. The gear-shifting position diagram is located on the top surface of the lever knob. The back up lamps operate when shifted to reverse with the starter switch "ON".



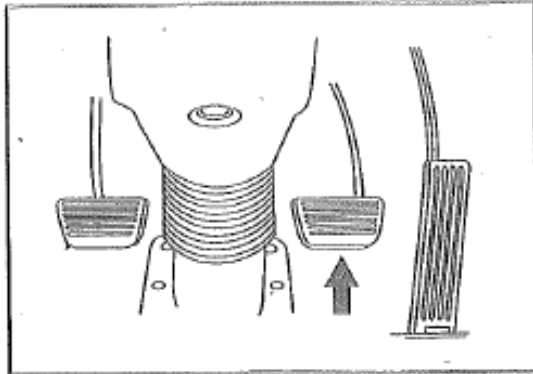
**Accelerator pedal**

To avoid unnecessary increase in fuel consumption, the accelerator pedal should be operated gradually.

**NOTE**

Before changing the reverse gear, the vehicle must be fully stopped.

**POWER STAR**

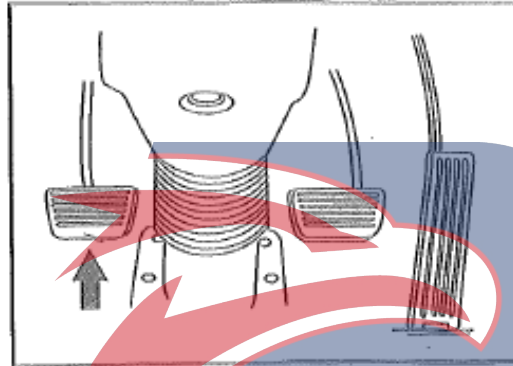


### Brake pedal

In order to avoid rapid braking, the brake pedal shall be operated smoothly.

#### NOTE

**If the engine stops running in the driving, the brake booster cannot fully play its role and thus reducing the braking effect. In this case, depress the brake pedal firmly in order to achieve the braking effect.**

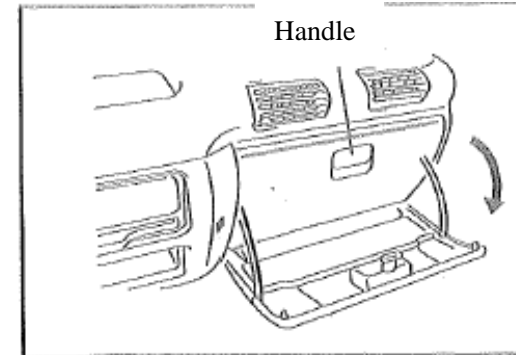


### Clutch pedal

The pedal should be fully depressed when disengaging. Otherwise, the friction sound can be sent, resulting in rapid wear.

#### NOTE

**Do not place your foot on the pedal when not using the clutch.**



### OTHERS

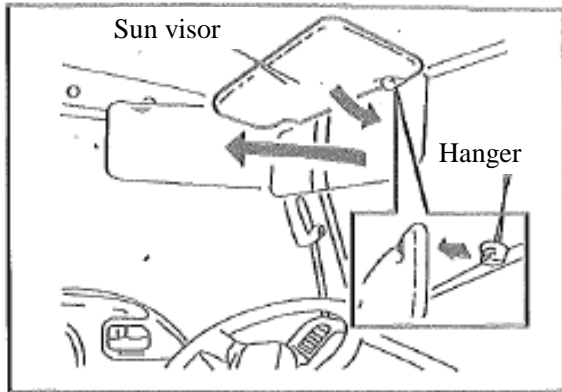
#### Case

The toolbox is mounted on the instrument panel end of the assistant side. Pull the handle on the upper part of the tool box cover, and the toolbox can be opened.

#### WARNING

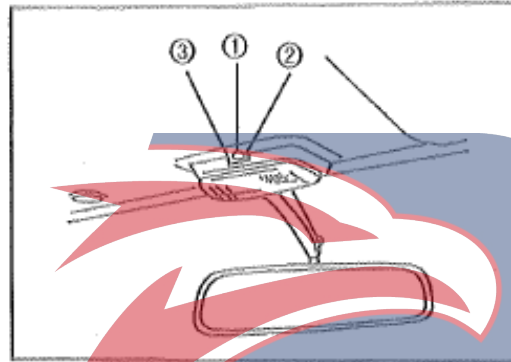
It is required to open the tool box while the vehicle is running, otherwise when emergency braking or accident occurs, the articles inside the toolbox may jump out and injure people.

# POWERSTAR



### Sun visor

If the sun shines your face, The sun visors may be swung down to prevent glare from the front or disconnected from the retainer and pivoted to the side window.



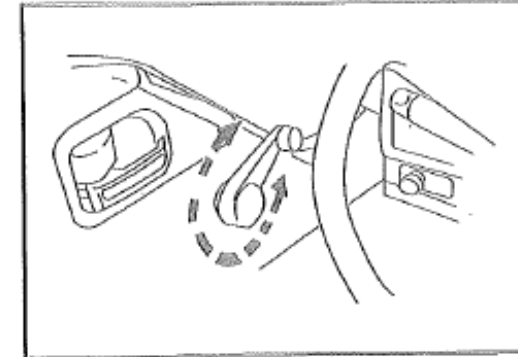
### Dome lamp

The dome lamp is operative at any starter switch position.

- ① "OFF": The lamp remains off.
- ② "DOOR": The lamp comes on when driver's door is opened.
- ③ "ON": The lamp remains on regardless of the door position.

### NOTE

When the dome lamp switch is placed in the "door" position, make sure that the door is fully closed to prevent the dome lamp from being illuminated at all times.

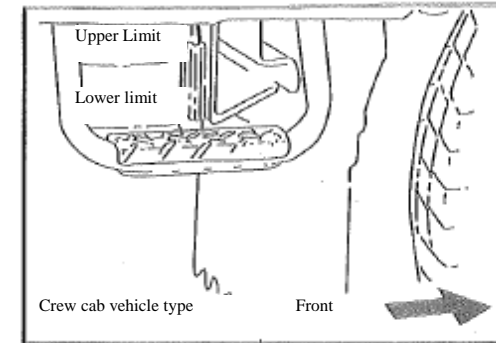
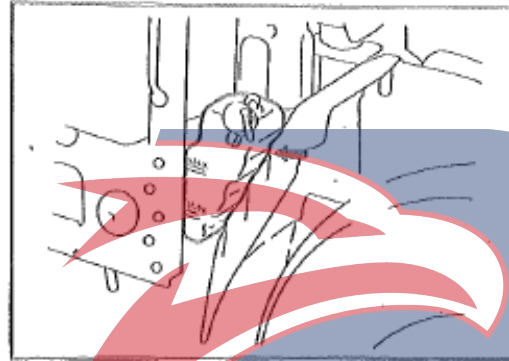
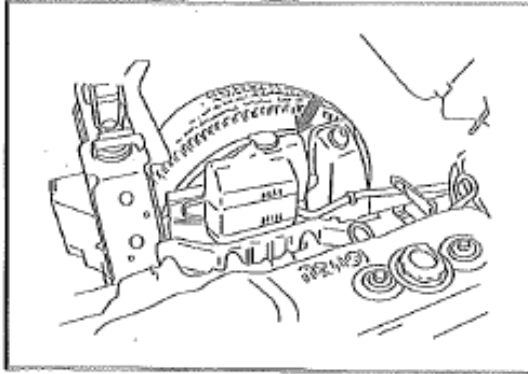


### Window regulator handle

To raise or lower the side window, turn the window regulator handle.

# POWERSTAR





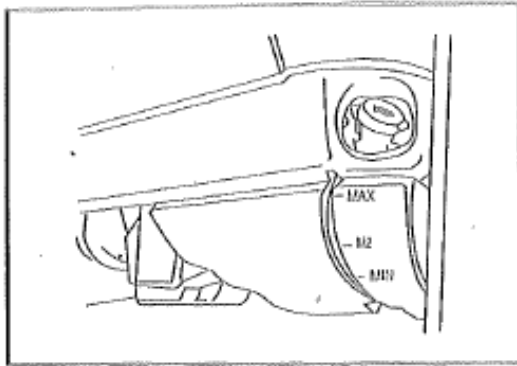
### Radiator backup water tank

The radiator backup tank is mounted on the left or right side of the cab or mounted on the right side of the cab (crew cab vehicle type).

#### **WARNING**

Check the coolant liquid level and add coolant liquid at the spare water tank, and if there is no special requirement, it is not necessary to remove the radiator filler cap. For details, see the Service and Maintenance section.

# POWERSTAR



#### Windshield washer tank

The windshield washer fluid tank is mounted under the auxiliary instrument panel.

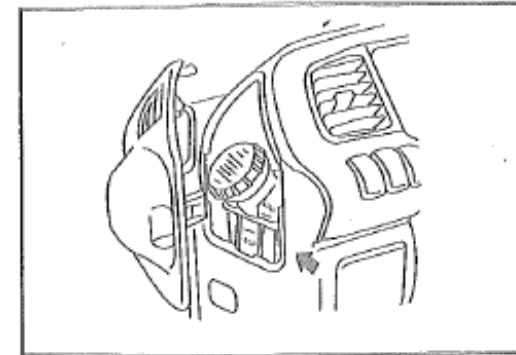
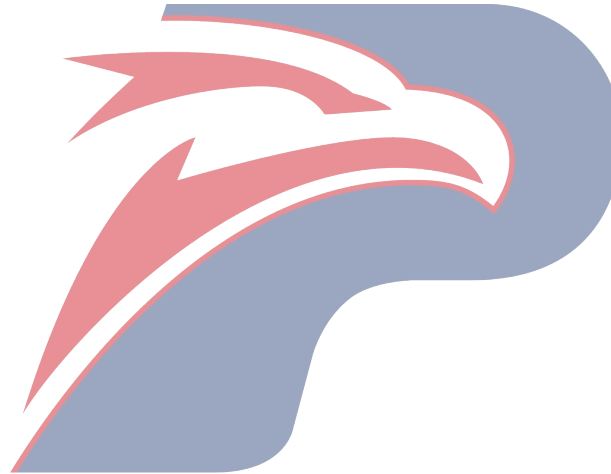
The washer tank should be filled only with plain water or Isuzu genuine washer solution.

#### CAUTION

- Do not use the radiator antifreeze in the washer liquid reservoir, in this way the paint surface will be damaged.
- Clean the ice and snow on the wiper blade before using the wipers.

#### WARNING

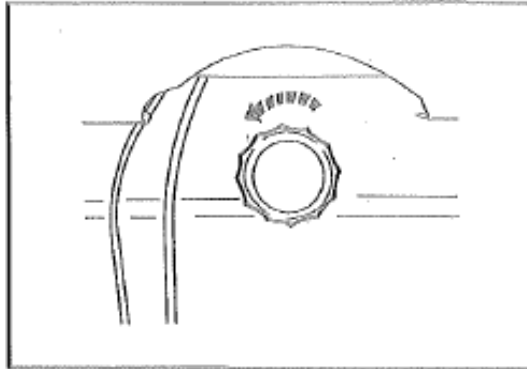
In the cold season, use the defroster to heat the windscreen before using the scrubber. This will be conducive to preventing freezing of the driver's vision.



#### Liquid storage tank for brake and clutch

This reservoir is mounted next to the dashboard on the driver's side.

# POWERSTAR

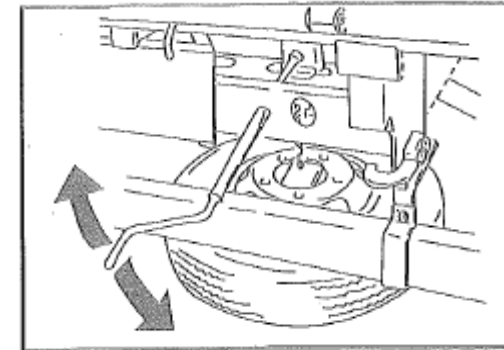
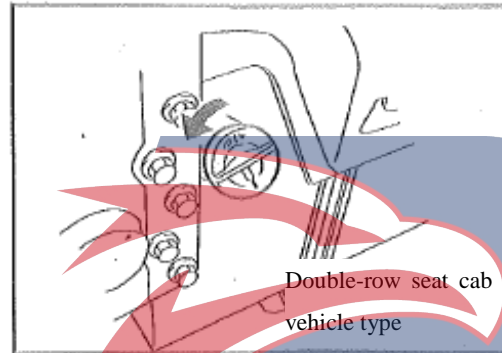


### Fuel tank filler cap

The fuel tank filler cap is located on the fuel tank. Remove the fuel tank filler cap by turning it counterclockwise.

#### **WARNING**

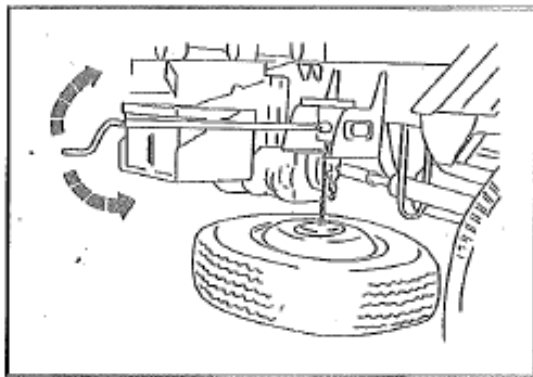
If you need to replace the fuel filler cap, use only a genuine QingLing fuel filler cap. The use of an improper fuel filler cap could cause fuel spillage in the event of an accident. The use of an improper fuel filler cap could also affect the fuel system and the emission control system.



### Spare tire hanger

The spare tire is fixed by chains to the rear of the frame or below the left side of the frame. To lower the spare tire, insert the handle into the hole in the back of the vehicle so that it is connected to the latch and turn the handle counterclockwise.

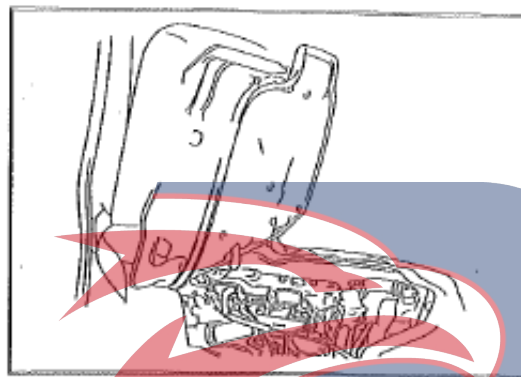
# POWERSTAR



To lower the spare tire, insert the handle into a hole in the side chassis frame to engage the catch and turn the handle counterclockwise. To raise, turn the handle clockwise to stop and give an additional turn to securely hold the spare tire in position of stowage.

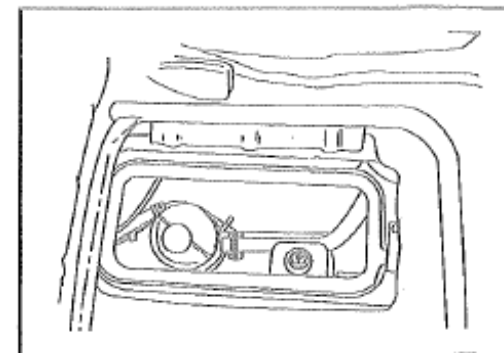
**WARNING**

**In order to prevent the spare tire from falling off and causing damage due to sudden stopping the vehicle or the accident, make sure that the spare wheel is firmly fixed to the stowed position.**



**Cover of the engine inspection hole**

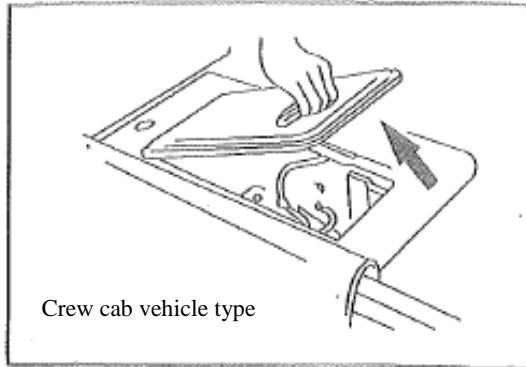
When you need to observe the engine in detail, loosen the buckle and then turn the entire seat cushion back and lift the engine to check the cover of the window aperture in order to check and adjust the engine.



**Auxiliary cover of the engine inspection hole**

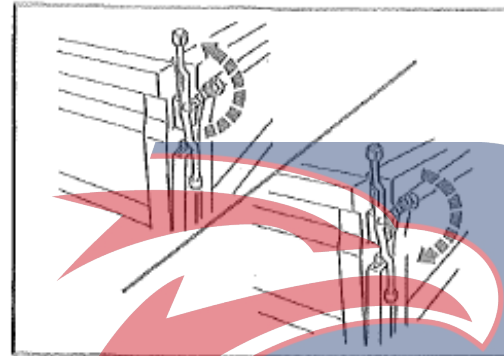
If further proximity to the engine compartment is required, it is possible to lift the seat cushion of the driver's seat and remove the engine check hole accessory cover.

**POWERSTAR**



**Inspection cover for battery and radiator backup water tank (crew cab vehicle type)**

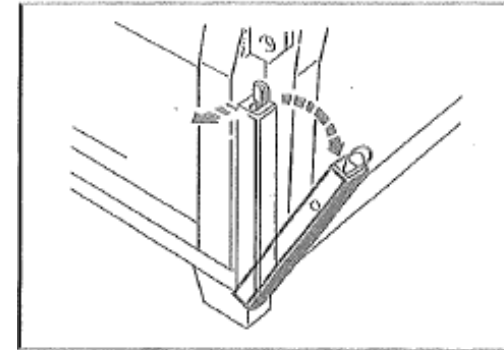
If it is necessary to close the storage tank near the battery and the radiator, raise the seat cushion for the rear seat and remove the inspection hole cover.



**Compartment (vehicle body)**

**Opening and closing operation of rear apron:**

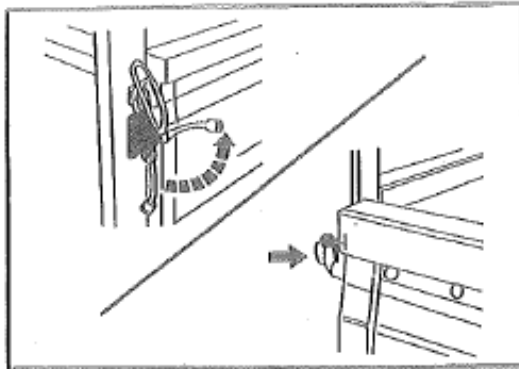
Turn the handle at the left and right up to 180 ° to release the striker and open the rear apron (board). To close, it is required to close the rear apron and then turn the handle downward to lock.



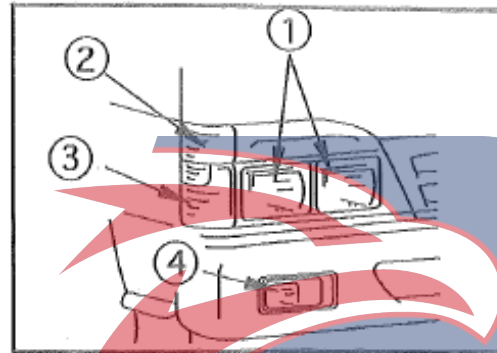
**Opening and closing of left and right side doors:**

1. Release the lock catch of the rear lock.
2. Push the locking handle to the left in order to push it outwards the lock to release the lock.

# POWERSTAR



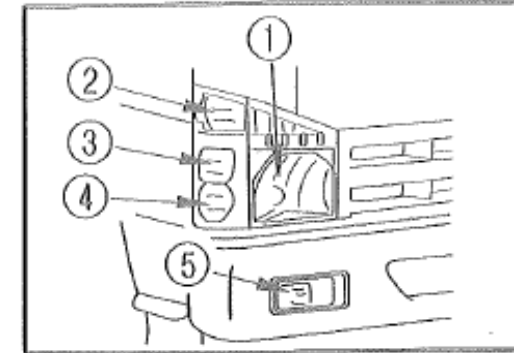
3. Lift up the hook handle at the front of the side board to release the front hook.
4. At this time, the front end of the side board is temporarily fixed by the clamp. Pull out the clamp in order to open the side board.
5. When the side door is closed, use the hook handle to reliably lock the front end of the side board, push into the vertical lock of the rear board with the handle.



**Exterior lamps**

**Front side:**

- 1 Headlights
- 2 Turn signal lamps
- 3 Clearance lamps
- 4 Fog lamps

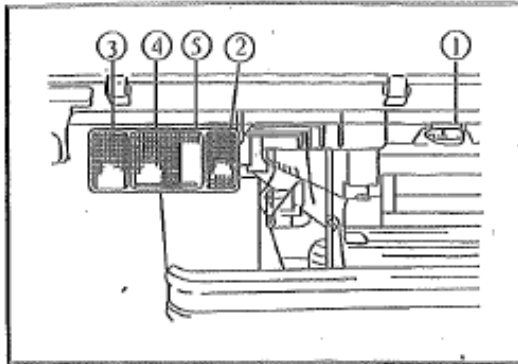


**Exterior lamps**

**Front side:**

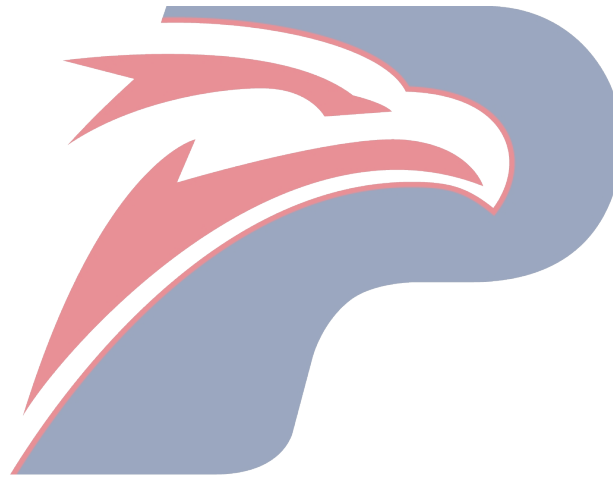
- 1 Headlights
- 2 Turn signal lamps
- 3 Clearance lamps
- 4 Cornering lamps
- 5 Fog lamps

# POWERSTAR

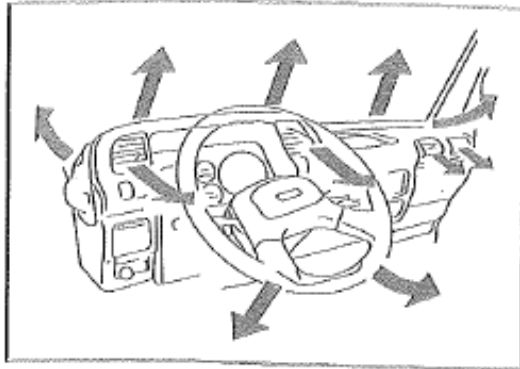


**Rear side:**

- ① License plate lamp
- ② Reversing lamp
- ③ Turn signal lamp
- ④ Tail lamp, brake lamp
- ⑤ Rear fog lamp

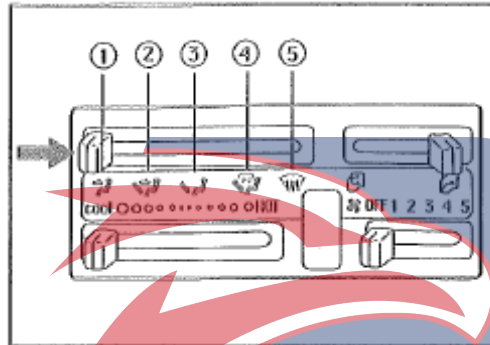


**POWERSTAR**



**Heater, defroster and air conditioner**

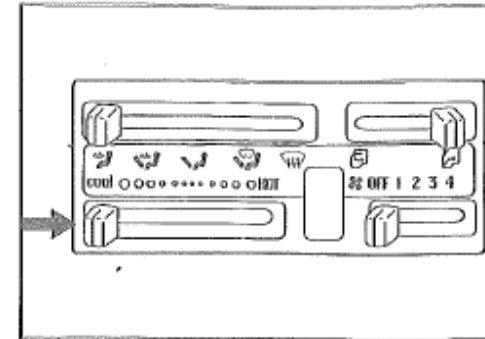
The air flows out from the outlets shown in the figure.



**Air outlet selection button**

The select button is used to control mode of operation.

- ①FACE: Air to your face
- ②BI-LEVEL: Air to your face and foot
- ③FOOT: Air to your foot
- ④FOOT/DEF: Air to your foot and windshield
- ⑤DEF: Air to windshield

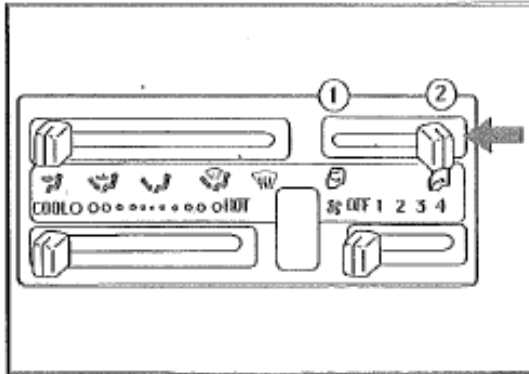


**Temperature lever:**

The temperature lever is for temperature control (through controlling of hot water flow rate).

# POWERSTAR

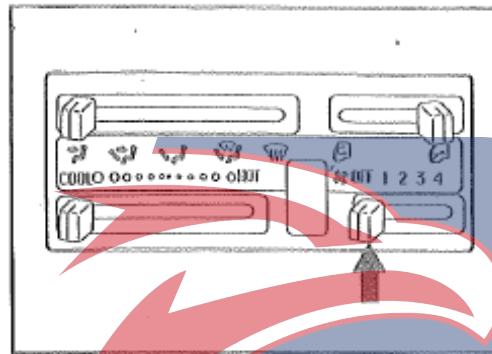




**Indoor and outdoor air change lever**

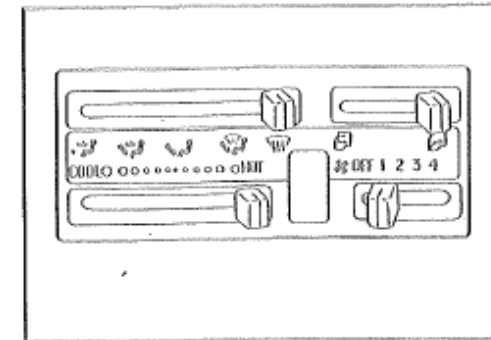
This handle is used to convert two ventilation modes that introduce external air or indoor air circulation.

- ① Cycle the indoor air.
- ② Introduce external air into the room.



**Blower fan switch:**

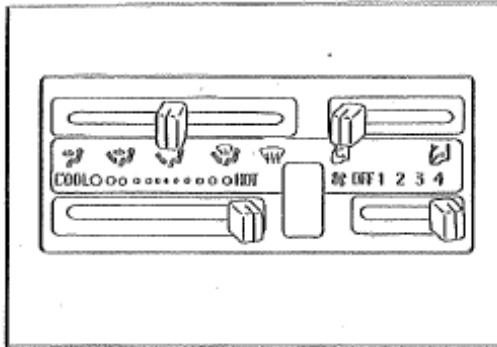
Fan switch can be divided into 4-stage to regulate the air volume.



**Windshield demisting:**

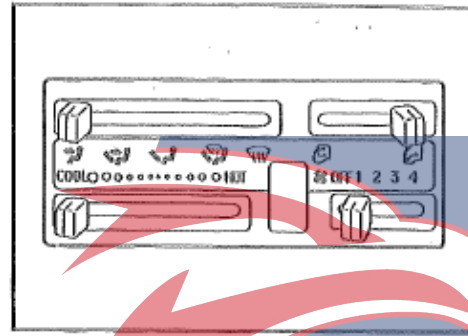
Place the air outlet □ selecting handle and the indoor and outdoor air changing- handle to the position shown in the figure, and then turn on the ventilator switch to use the windshield anti-fog device.

# POWERSTAR



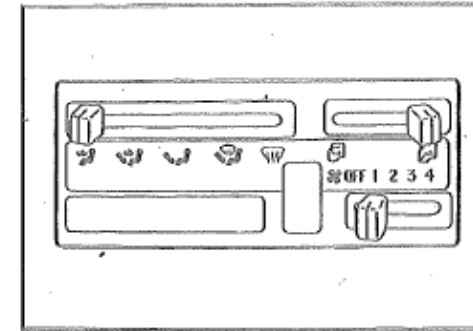
**Heating:**

Turn the thermostat handle to the position shown in the illustration and turn on the fan switch. In case of rapid heating, the indoor and outdoor air change-over switch can be placed in the position shown in the figure, and then switch the ventilator switch to "4" position.



**Ventilation: (equipped with heating device)**

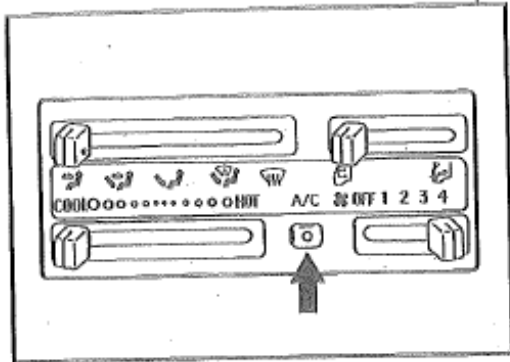
When the indoor and outdoor air conversion handle is placed in the position as shown in the figure, the external air can be introduced, if the ventilator switch is pushed to the ON position, the forced ventilation can be conducted.



**Forced ventilation:**

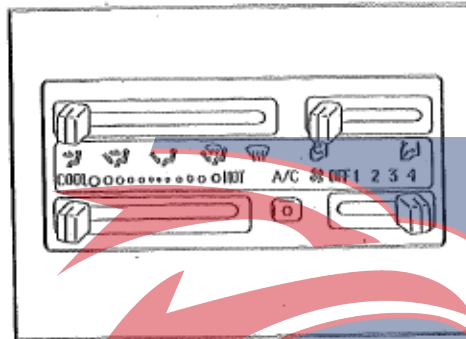
The ventilator switch can be placed in any position other than the "OFF" position, and the indoor and outdoor air change handle shall be placed in the position as shown in the figure, and fresh air can be introduced from the outside.

# POWERSTAR



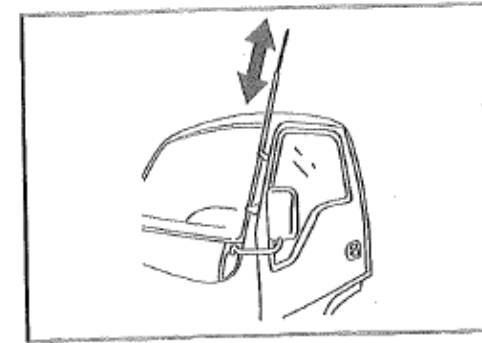
**OPT Room temperature control (on model with air conditioner):**

The room temperature can be adjusted to the desired temperature. To turn on, push the "A/C" button in, and to turn off, push the button in once more.



**Cooling (on model with air conditioner):**

Push the "A/C" button in and set the temperature lever as shown in the figure. To cool the room quickly, set the air source select button to "Circulation" position and set the blower fan lever to "4" position.

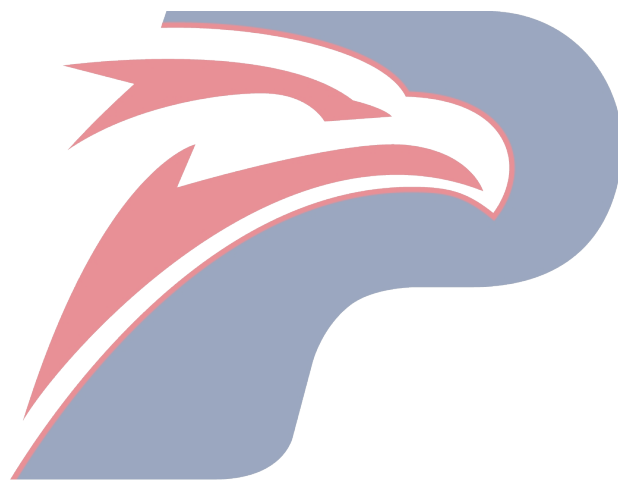


**Antenna:**

Pull out the antenna for better reception.

If the vehicle is parked in a garage with low roof or is washed, the antenna should be retracted.

# POWERSTAR

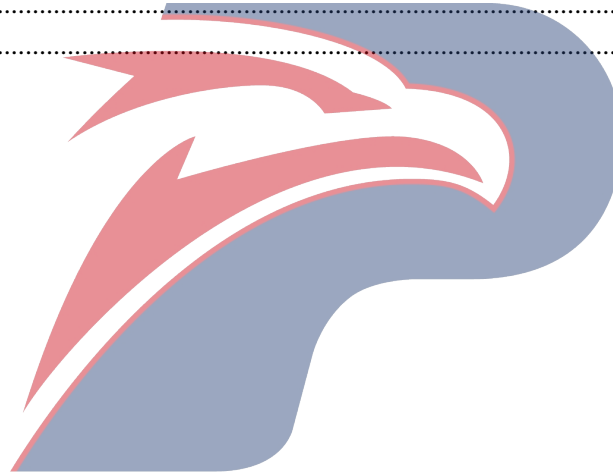


***POWERSTAR***



### **3 BEFORE DRIVING YOUR VEHICLE**

OPERATION OF CONTROLS .....3-2  
DRIVER'S CHECK LIST (ROUTINE INSPECTION) .....3-9

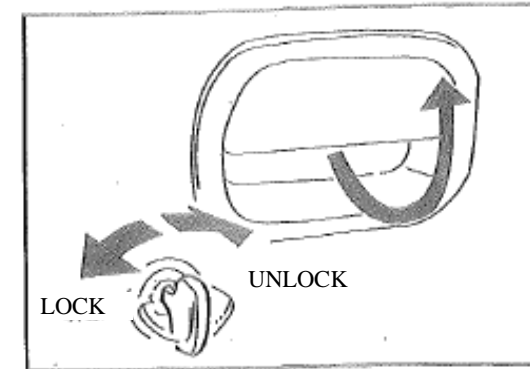
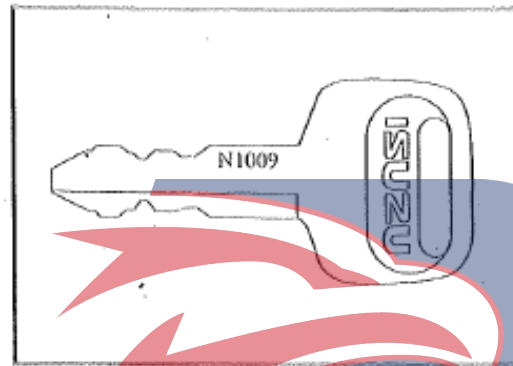


# **POWERSTAR**



## BEFORE DRIVING YOUR VEHICLE

Proper care and driving pay not only to extend the service life of your vehicle, but also improve fuel and oil economy. Drive carefully and defensively.



### OPERATION OF CONTROLS

#### Key

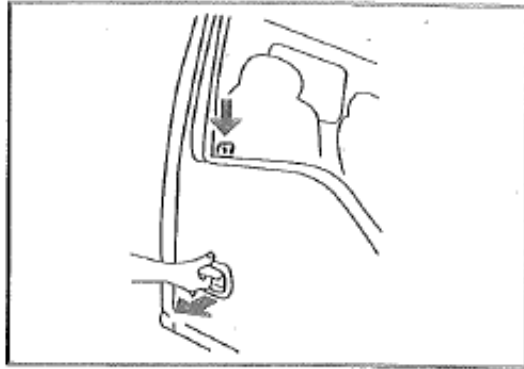
This key is used to operate the start switch and door lock. The code number of each key is stamped on it. Record the key number and keep it in a safe place such as your wallet, **NOT IN THE VEHICLE.**

#### Outside door handle

Pull the outside handle of the door outward to open the door.

They can be locked by inserting the starter switch key in the door key lock and turning it.

# POWERSTAR

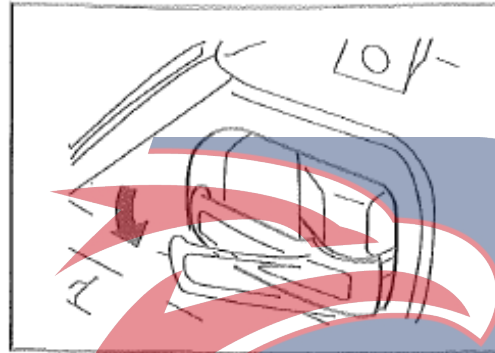


#### Door lock (outside)

The door can be locked outside without the key. The method is to press the door lock knob on the inside of the vehicle into the "LOCK" position, and pull the outside handle of the door outward, and close the door.

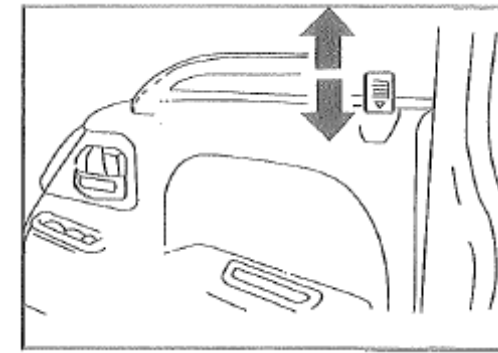
#### NOTE

Be careful not to lock your keys in the vehicle.



#### Inside door handle

The doors can be opened by pulling the inside door handle.



#### Door lock (inside)

The doors can be locked by setting the door lock knob after closing the door.

#### WARNING

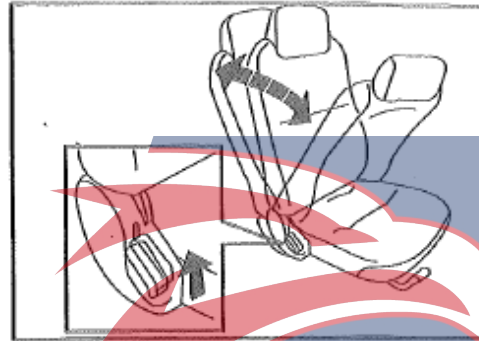
- When driving, ensure that all doors are locked. After the doors are locked, the maximum protection for passengers and drivers will be provided. If a seat belt is fitted, use it correctly. After all doors are locked, no one will be thrown out of the vehicle in case of accident. When the vehicle is suspended, the locking door can also prevent the invasion of the mob.
- When leaving the vehicle, it is required to turn off the engine and lock all doors.

# POWERSTAR



#### Driver's seat

The seat can be adjusted fore and aft with the lever pulled upward. Body leaned on the seat and move the seat to adjust to the suitable position.



When required, the front seat back recline can be tilted back through the adjustment lever on one side of the front seat door. Lift the adjustment lever and turn the front seat back against the back. When the adjustment lever is raised again, the front seat back can be pulled back to the upright position.

When the seat back moves forward or backward, care should be taken to avoid interference in the seat and seat belt and belt buckle. This will be conducive to preventing damage to the seat belt mechanism.

#### WARNING

- When you manually adjust the seat, use your body weight to pull the seat back and forth to ensure that the seat adjuster is buckled. If the seat shakes, it indicates that at least one regulator tooth is not engaged, which increases the likelihood of injury and the degree of accident injury. If your seat adjuster cannot be fastened, please send the vehicle to the QingLing Motors Dealer (Maintenance Station) for maintenance.
- Do not attempt to adjust the seat when the vehicle is running. This may cause a sudden movement of the seat so that you lose control of the vehicle.

# POWERSTAR

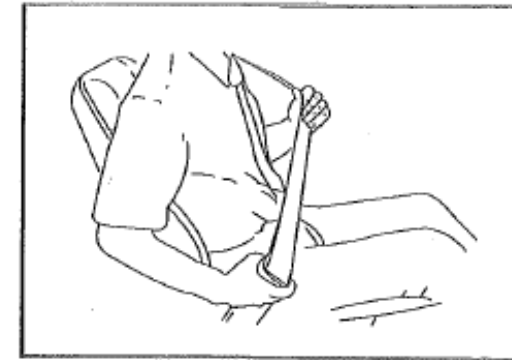
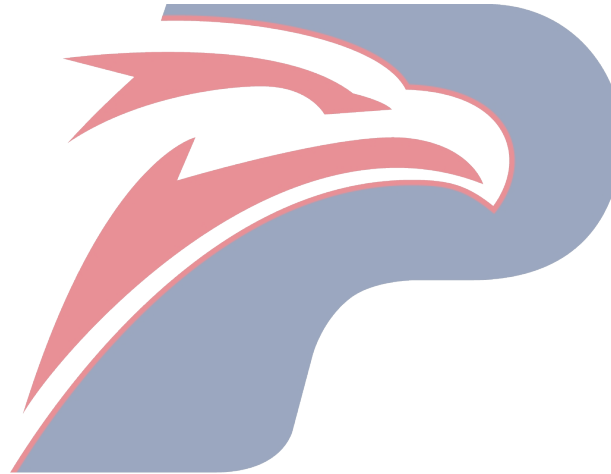




#### **WARNING**

- In order to reduce the probability of injury and/or the degree of injury in accident, the safety belt shall be closely attached to the body and lowered to its position as far as possible. In this way, the force generated from the seat belt will be distributed on a strong pelvic bone, not distributed in the abdomen.
- Never use a seat belt for more people at the same time. Because of the use of a safety belt for two people, adequate protection cannot be provided in the event of an accident.
- Care must be taken not to allow the seat belt or the buckle to be clamped by the seat hardware or the door in order to avoid damage.

- If the belt length is too loose, it will not hold your body effectively and increase the probability of injury when the accident occurs.



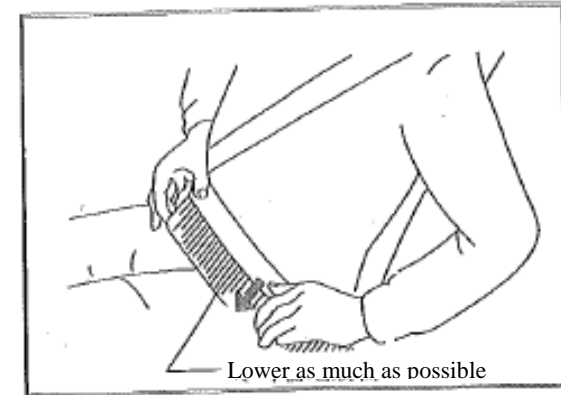
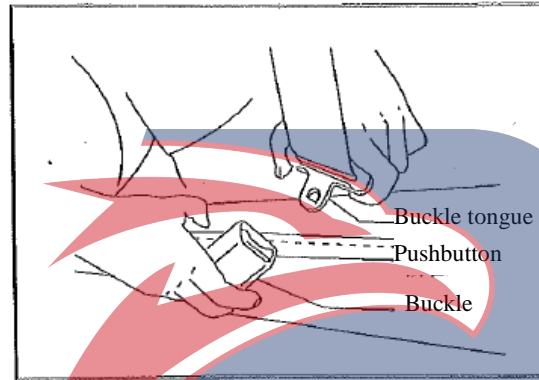
#### **Seat Belt (3-Point)**

1. Adjust the seat as needed and sit up straight and well back in the seat. Hold the buckle tongue to perform the following steps:

- ① Pull the seat belt to the wind the lower hip position.
- ② Hold the buckle tongue piece on the seat belt so that it slides along the seat belt at right angles to the seat belt and further pulls forwards.

# POWERSTAR

③Then slowly pull the buckle tongue piece across your body and insert it into the open-end of the buckle until the "snap-up" sound is issued. If before the buckle tongue piece reaches the buckle, the seat belt cannot be pulled out because of the locking of the retractor, then the seat belt shall be slamply retracted, then pull the buckle tongue more slowly than the last speed.



2. In order to reduce the danger of the user from slipping out of the seat belt when the vehicle is impacted, the seat belt shall be positioned as far as possible to wind the lower hip position and the safety belt shall be pulled upward to the shoulder by the buckle tongue so that the safety belt snugs against the body.

The waist shoulder belt shall automatically lock the stretching of the seat belt during emergency braking or vehicle collision. Usually it moves freely with the user.

3. Press the button on the buckle to release the safety lock. When the buckle is released, the seat belt will retract the device. In order to prevent touching person or the nearby goods during contraction, the buckle tongue shall be held to retract the seat belt. To prevent damage to the seat belt and interior trim, it is required to verify that the seat belt has been fully retracted before closing the door and that the buckle tongue has not become a barrier.

**POWER STAR**

**CAUTION**

**To reduce the risk of personal injury when an accident occurs, the child should be moved away from the middle of the shoulder belt if the shoulder belt portion is in or is very close to the face or the neck of the child.**

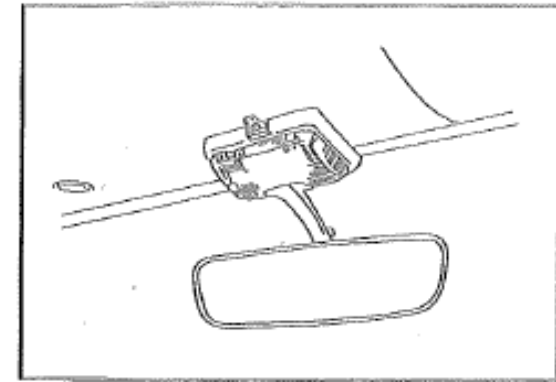
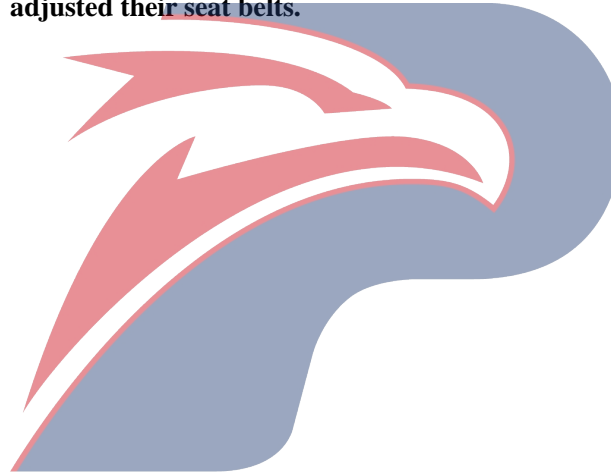


### Seat belt inspection and care

- Periodically inspect belts, buckles, latch plates, retractors, and anchors for damage that could lessen the effectiveness of the restraint system.
- Keep sharp edges and damaging objects away from belts.
- Replace belts if cut, weakened, frayed, or subjected to collision loads.
- Check that anchor mounting belts are tight to the floor.
- Have questionable parts replaced.
- Keep seat belts clean and dry.
- Clean only with mild soap solution and lukewarm water.
- Do not bleach or dye belts since this may weaken belts.
- Attention shall be paid to preventing the belt from being contaminated by the polishing oil or organic chemicals, especially battery electrolyte.
- Do not modify or add anything to the safety belt, which may affect the function of the safety belt.

### CAUTION

**You should know how to correctly use the seat belt, which is very important. At the same time, whenever the vehicle is running, you should also ensure that all passengers have properly adjusted their seat belts.**

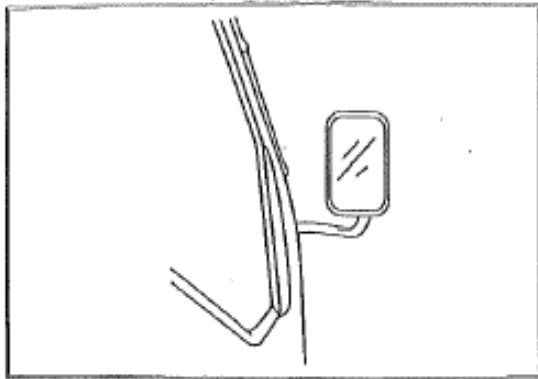


### Mirrors

#### Inside rearview mirror

To adjust, push the mirror right or left, and up or down.

# POWERSTAR

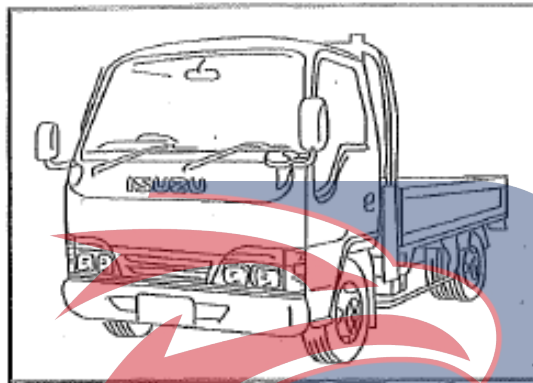


#### Outside rearview mirrors

Adjust the outside rearview mirrors so you can see not only each side of the road behind you, but also each side of your vehicle. This helps you determine your relation to the objects behind.

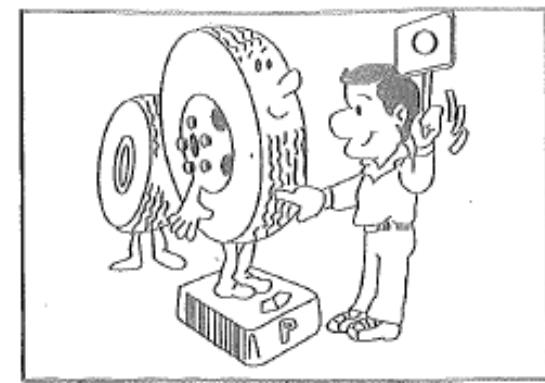
#### **WARNING**

**Do not adjust the exterior rear-view mirror during driving**



#### **DRIVER'S CHECK LIST (ROUTINE INSPECTION)**

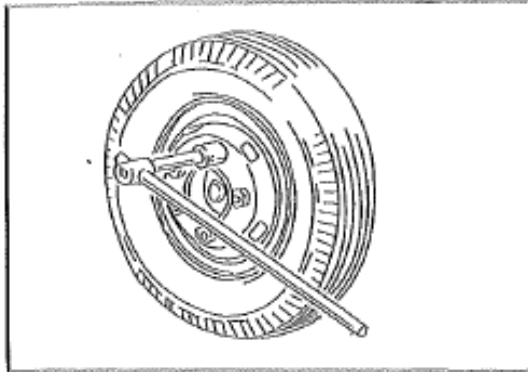
The following checks should be performed to maintain safe and dependable vehicle operation (Refer to "MAINTENANCE GUIDE" for proper check-up procedures).



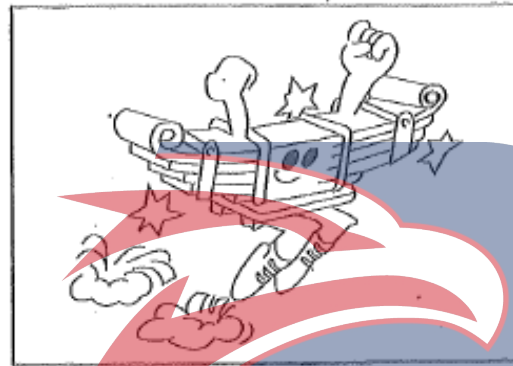
#### Exterior

1. Check tires for inflation pressure and damage.

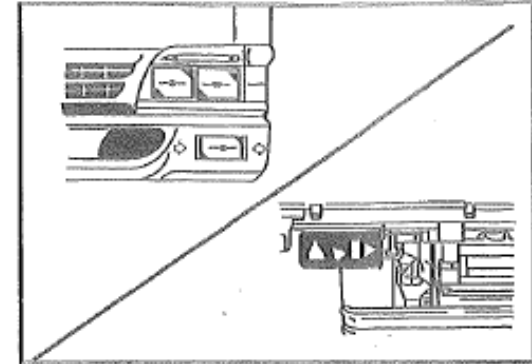
# POWERSTAR



2. Check wheel nuts for looseness.

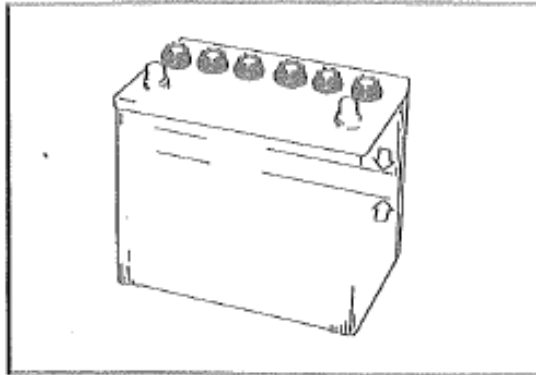


3. Check chassis springs for damage.

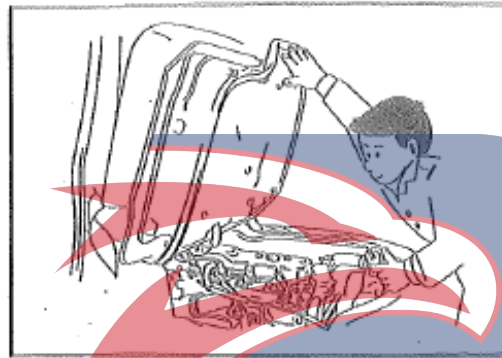


4. Check operation of lamps.

# POWERSTAR



5. Check level of electrolyte in each cell of the batteries.



6. Check for oil, coolant, fuel, brake fluid and/or power steering fluid leaks.

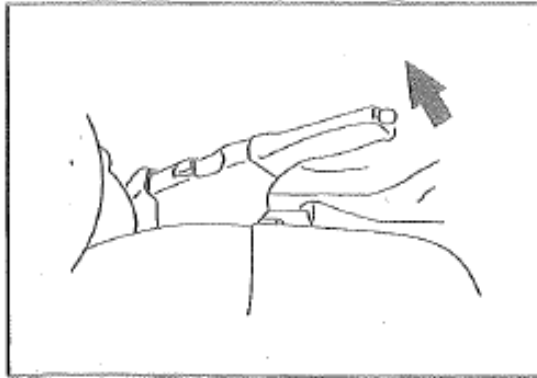


**Inside the cab**

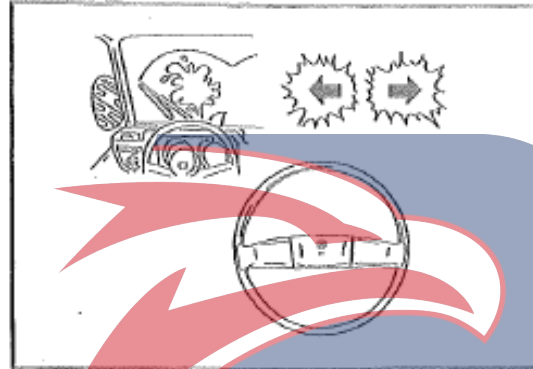
1. Check for steering wheel free play and looseness in mount.

If the vehicle is equipped with a power steering gear, The wheel free play should be checked with the engine running.

# POWERSTAR



2. Check parking brake lever travel and function.

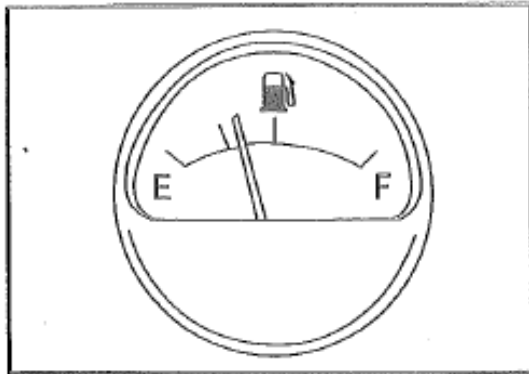


3. Check operation of horns, windshield wipers and turn signals.



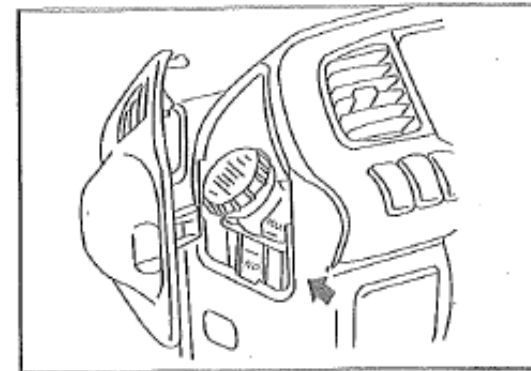
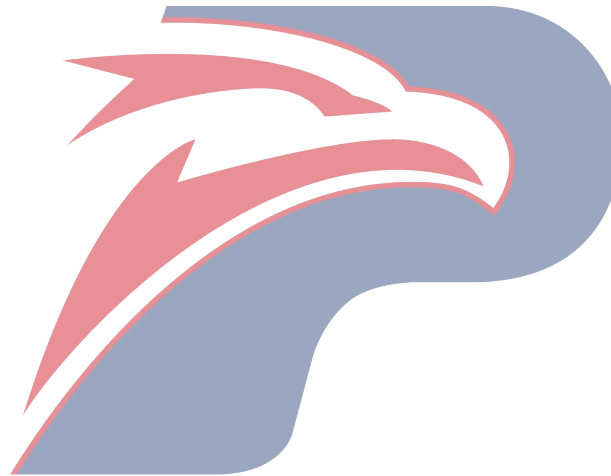
4. Check operation of instruments and indicator lamps.

# POWERSTAR



5. Check level of fuel in the fuel tank against fuel gauge.

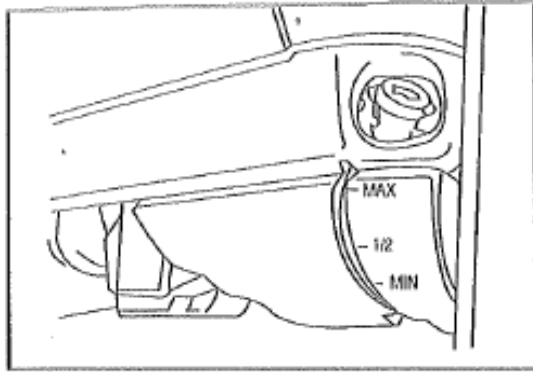
6. Check whether the setting angle of each mirror is appropriate or not.



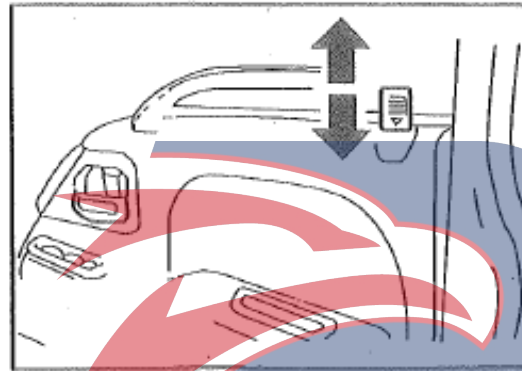
7. Check whether the fluid level in the reservoir is normal.

# POWERSTAR

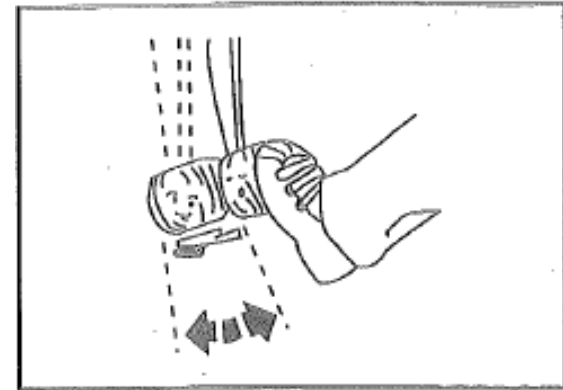




8. Check level of windshield washer solution in the tank.

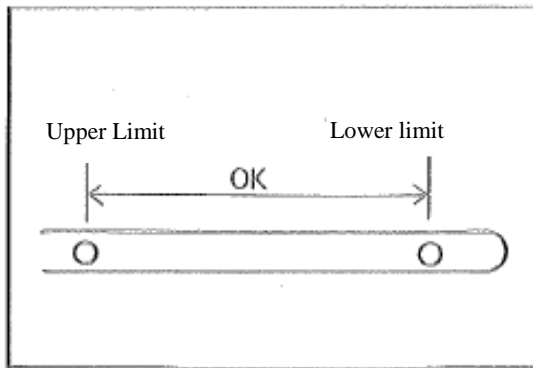


9. Check operation of door locking mechanism.



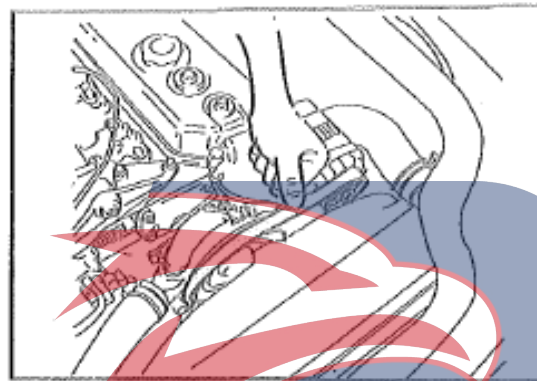
10. Check clutch pedal free play and function.

# POWERSTAR

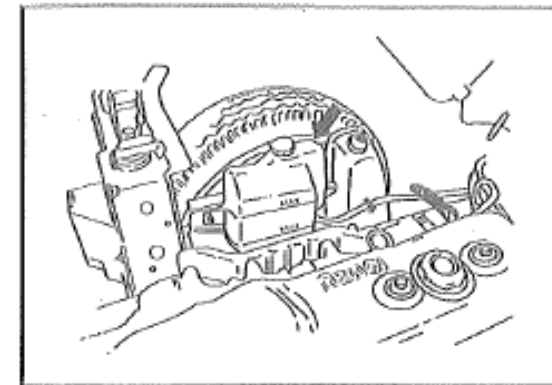


**Inside the engine compartment**

1. Check engine oil level.

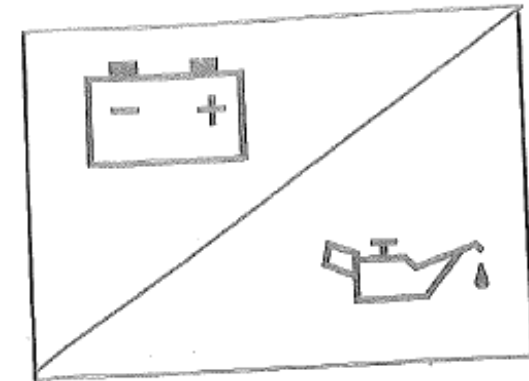
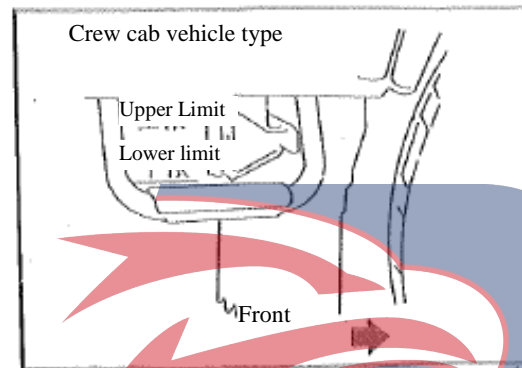
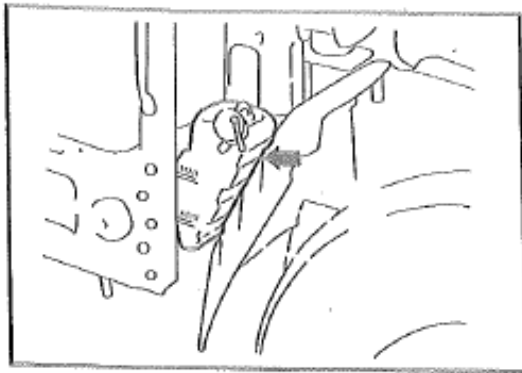


2. Check fan belt tension.



3. Check whether the engine coolant level and radiator cap are loose.

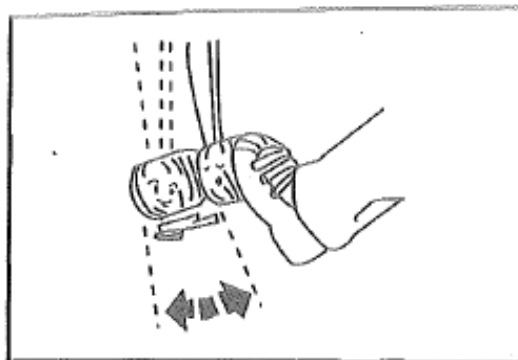
# POWERSTAR



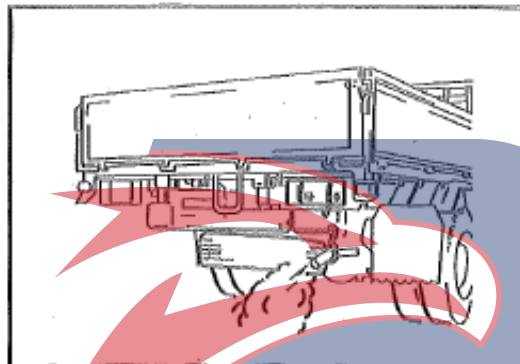
**After starting engine**

1. With the engine running, check that the indicator lamps go out and remain out.

# POWERSTAR



2. Check brake pedal free play and function.



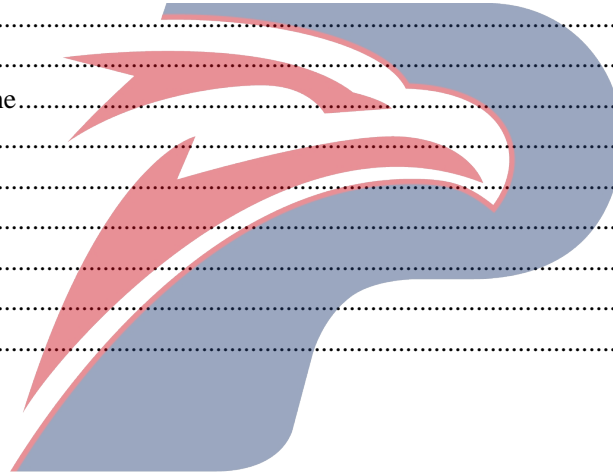
3. Check for abnormal engine noise and color of exhaust gases.

# POWERSTAR



## 4 DRIVING

Preparation for starting engine .....	4-2
Starting engine.....	4-3
Stopping engine.....	4-3
Before driving off.....	4-4
Precautions for the operation of the turbo charging engine.....	4-5
Parking .....	4-5
Driving precautions .....	4-6
Driving for economy .....	4-10
Operation and care in winter .....	4-11
Driving on ice or snow .....	4-13
In case of emergency .....	4-14

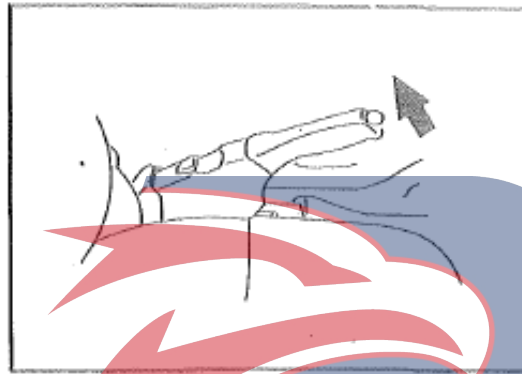


# POWERSTAR



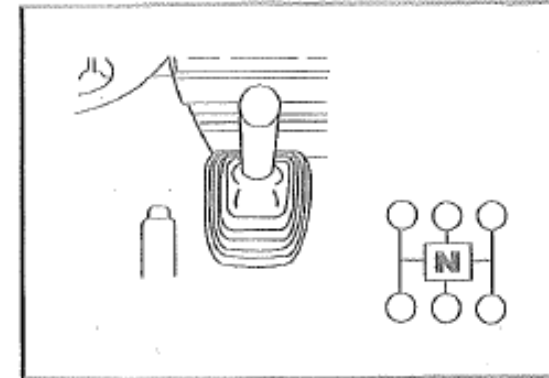
## DRIVING

Proper care and operation will not only extend the service life of your vehicle, but also improve oil and fuel economy.



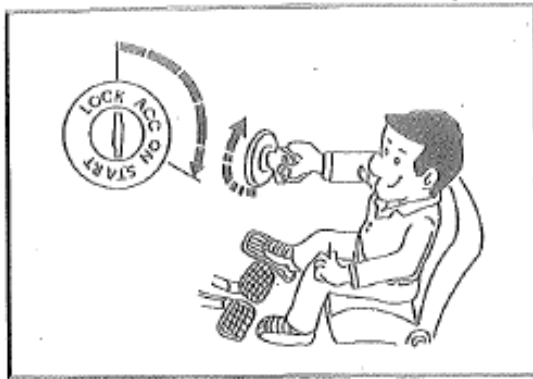
### PREPARATION FOR STARTING ENGINE

1. Tighten the parking brake lever.



2. Place the transmission in neutral.

# POWERSTAR

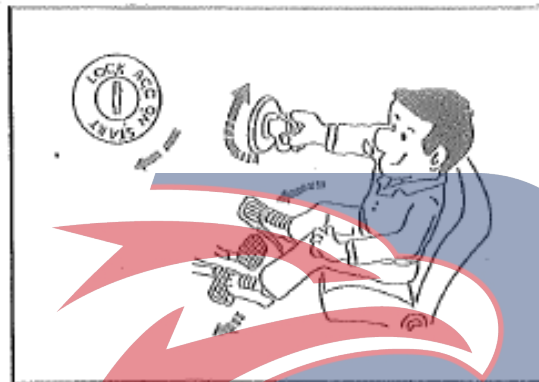


### STARTING ENGINE

1. When the start switch is turned to the ON position, the warm-up indicator will illuminate and turn off after approximately 0.5 seconds (engine in warm-up status) or 4.0 seconds (engine is cold).

#### CAUTION

Do not depress the accelerator pedal at this time. If the accelerator pedal is pressed before the start switch is turned on, it is difficult to start the engine smoothly due to that the "starting oil supply increment" device cannot function normally.

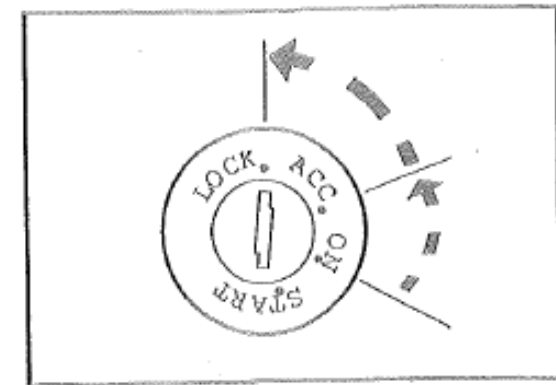


2. The start switch remains in the "ON" position for 2 seconds and the preheating indicator is off., Start the engine by turning the key to the "START" position with the clutch and accelerator pedals depressed fully.

#### CAUTION

Do not allow the starter to operate for more than 10 seconds, otherwise the starter and the battery will be adversely affected and it is required to wait for more than 1 minute to repeat the operation from step 1.

If you do not let the gear stay in "ON" position, and directly turn it to the "START" position, you may cause difficulties in starting the vehicle.

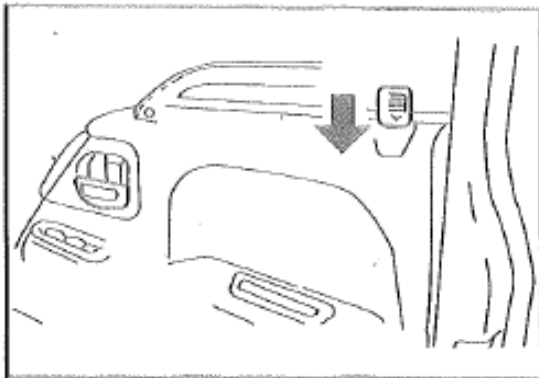


### STOPPING ENGINE

Turn the start switch to the "ACC" (accessories) or "LOCK" position.

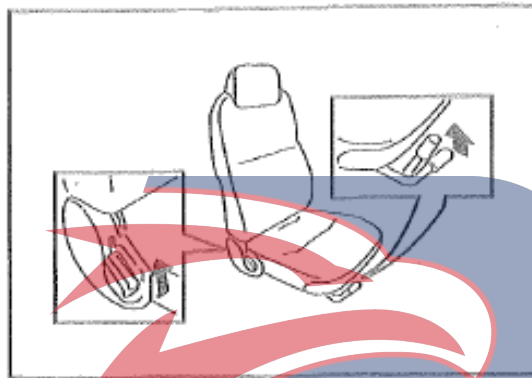
#### NOTE

If the engine gives a sign of overheating, do not stop it immediately and keep it running at a fast idle for a while.

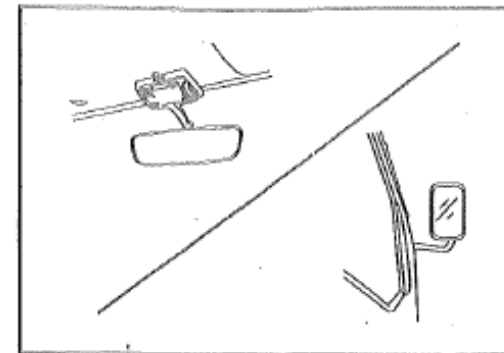


**BEFORE DRIVING OFF:**

1. Lock all doors.



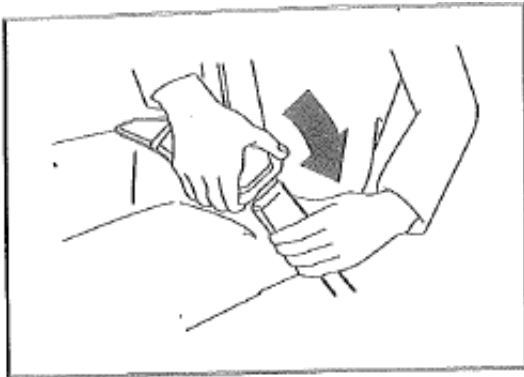
2. Adjust the seat position.



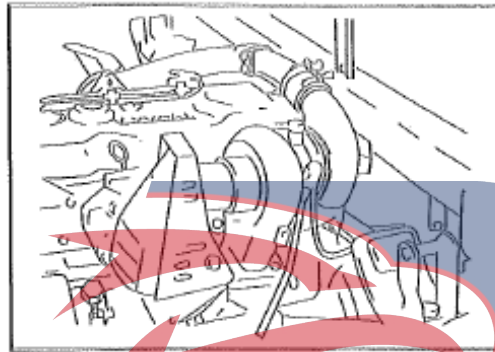
3. Adjust the inside and outside mirrors of the cab.

**POWERSTAR**





4. Fasten the safety belt.



#### **Precautions for the operation of the turbo charging engine**

##### **Engine starting**

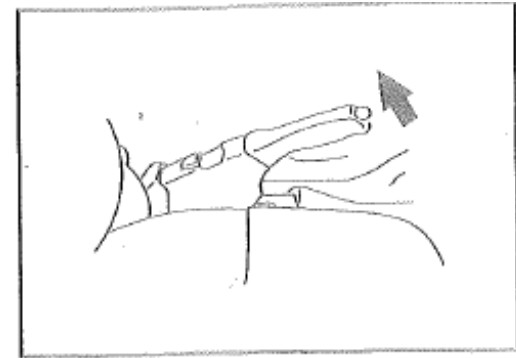
The turbocharged engine should be started to ensure the bearings supporting the rotating parts of the turbocharger are sufficiently lubricated.

Do not race a cold engine.

##### **Engine stopping**

#### **CAUTION**

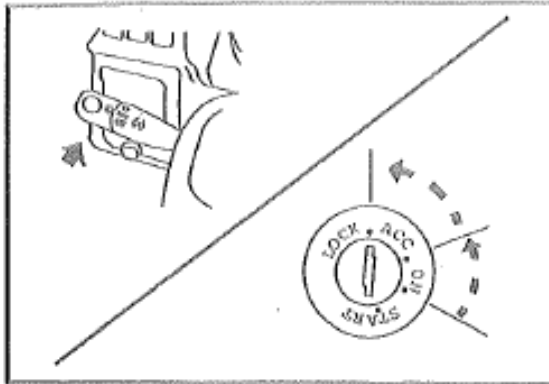
After driving high way, at least 3 minutes of operation should be at idle until it cools down. This allows turbocharger to return to idle speed while engine oil pressure is available for lubrication and will prolong the life of the turbocharger bearings.



#### **PARKING**

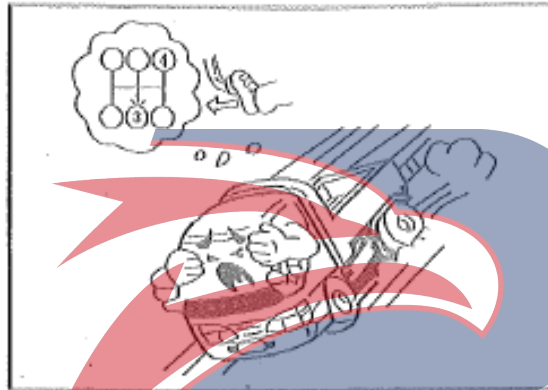
When leaving the unattended vehicles:

1. Pull up the parking brake lever.
2. As for the vehicle with manual transmission, when it is parked on an uphill, the shift lever shall be placed in the first gear. When parking on a downhill, the shift lever shall be placed in the Reverse position.
3. Turn the start switch key to "LOCK" position.
4. Take the key away.
5. Close all windows and lock all doors.
6. Check and ensure that the lamp is off.
7. If the vehicle is parked on a slope and leaves it unattended, the wheel stop must be padded.



**WARNING**

- Do not leave unattended children in the vehicle alone, and children may operate the control device on the vehicle to cause an accident.
- Do not drive or park the vehicle on flammable materials like hay or dry leaves, or run over it at idle speed, because the flammable materials may contact the high temperature exhaust system to cause combustion.
- Do not leave the vehicle while its engine is running, and make the vehicle unattended. If you are not working on, the engine will cause damage to the vehicle and the internal parts when the engine is operating until the temperature alarm lamps up or when the water temperature alarm lamp shows overheating.



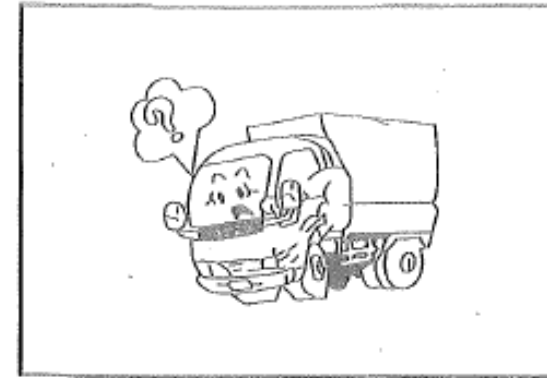
**DRIVING PRECAUTIONS**

1. Avoid over-running the engine.

When descending a slope pay close attention to prevent the engine from overrunning, particularly when making a downshift as the engine becomes liable to over-run.

**WARNING**

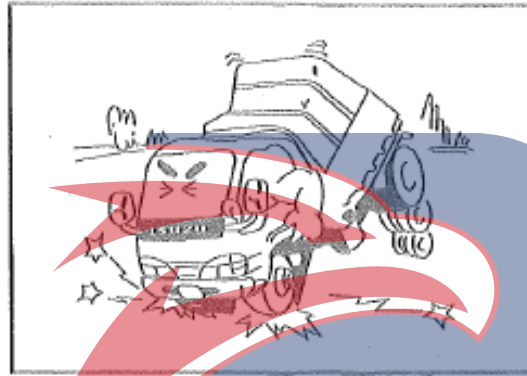
During driving, it is strictly prohibited to coast in Neutral position. Otherwise, it is easy to cause engine, vehicle fault and driving safety.



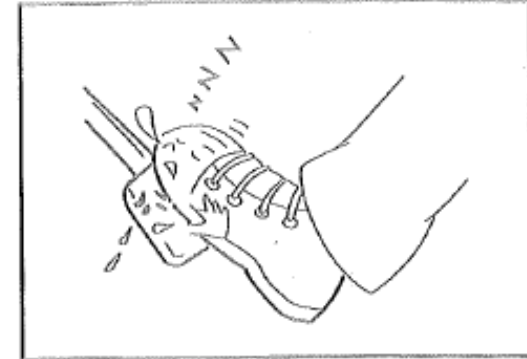
2. If abnormal noise or smell becomes noticeable while driving, stop the engine and check to locate the cause of the trouble.



3. If the indicator lamps or instruments give an indication of abnormal condition while driving, stop the engine and check to locate the cause of the trouble.

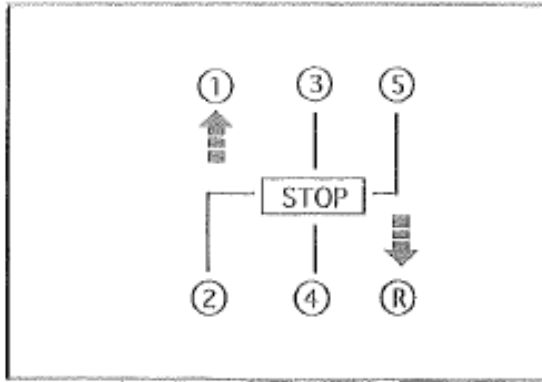


4. Avoid needless hard acceleration and hard stops.

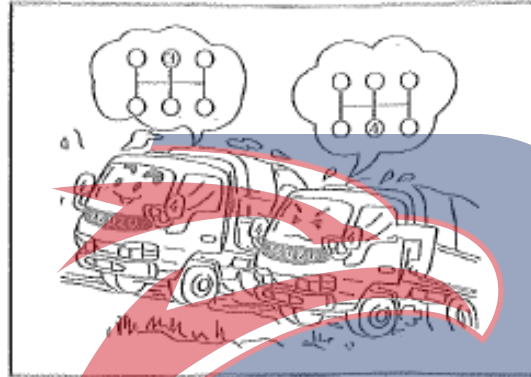


5. Do not drive with your foot resting on the clutch pedal as it produces a partly disengaged condition, causing premature wear of clutch facing.

# POWERSTAR



6. The vehicle should be completely stopped before shifting from forward gear to reverse or from reverse to forward.

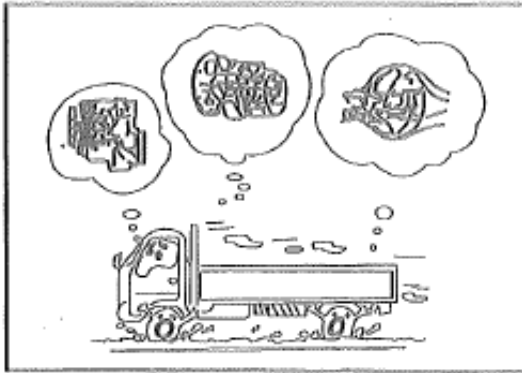


7. When climbing a slope, shift to lower gear to relieve the engine from overload before it begins to strain.



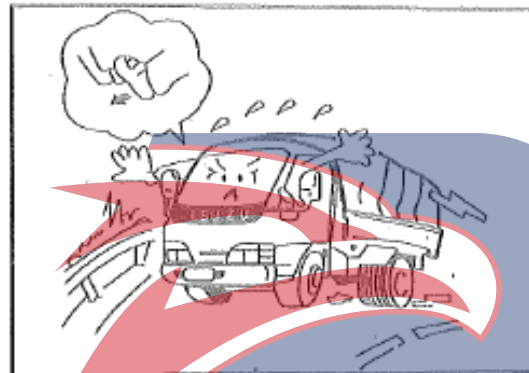
8. When descending a slope, shift to lower gear to gain retardation effect of the engine.

# POWERSTAR

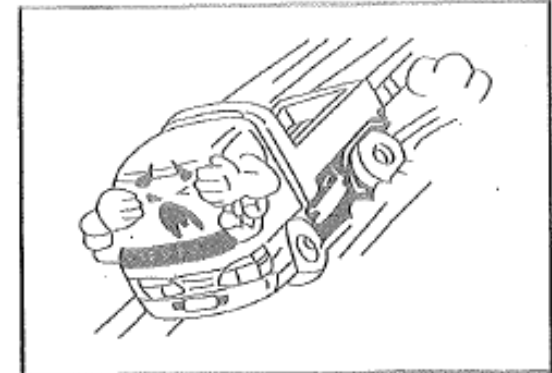


9. When crossing the shallow river or deep water pit during driving, special care shall be taken, otherwise water may enter the air passage to cause serious damage to the engine. After crossing water it is required to check the vehicle to confirm whether water enters the gear oil of the rear axle and the transmission.

If water is present, it shall be drained and the specified gear oil shall be added again.

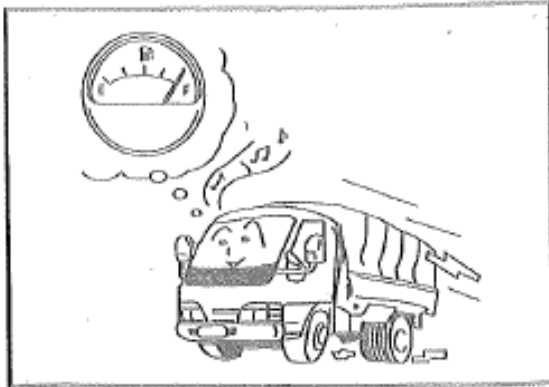


10. When driving in heavy rain or through shallow rivers, special care must be taken because the wet brake will temporarily weak the braking force.



11. Never stop the engine in the driving. Otherwise, brake efficiency will decrease due to stop operation of brake booster. If the start switch is turned to the "LOCK" position in the driving, it will cause a great danger, because the steering wheel is locked and cannot control the vehicle.

# POWERSTAR

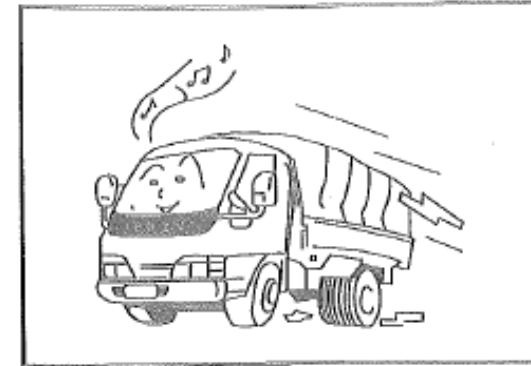


#### **DRIVING FOR ECONOMY**

1. Unnecessary high-speed driving and slow driving in high gear will result in excessive fuel consumption.

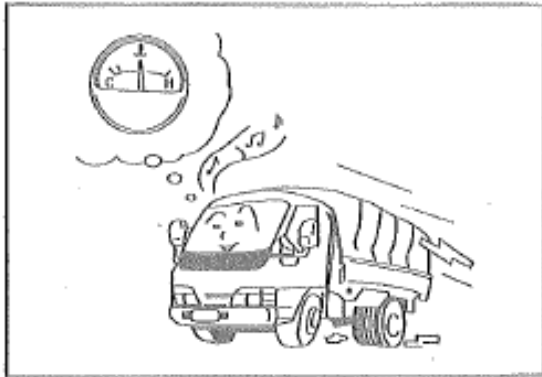


2. After acceleration, shift the shift lever into high gear and slowly release the clutch pedal.

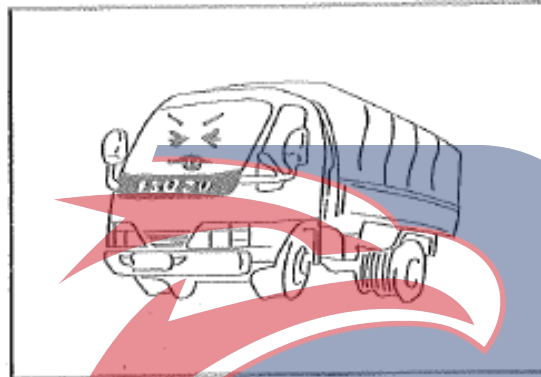


3. It is strongly advisable to keep your speed as constant as possible after shifting into top or overdrive gear.

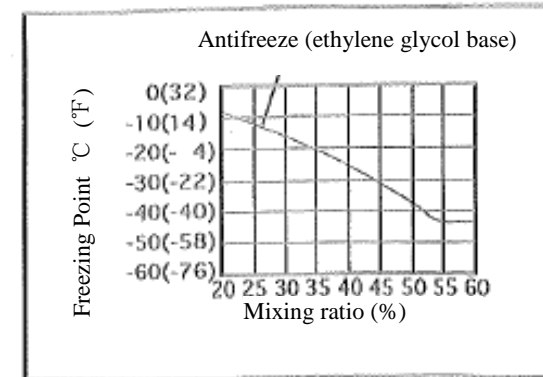
# POWERSTAR



4. Always drive with the coolant temperature kept within normal range.



5. Under-inflated tires cause deterioration in fuel economy.



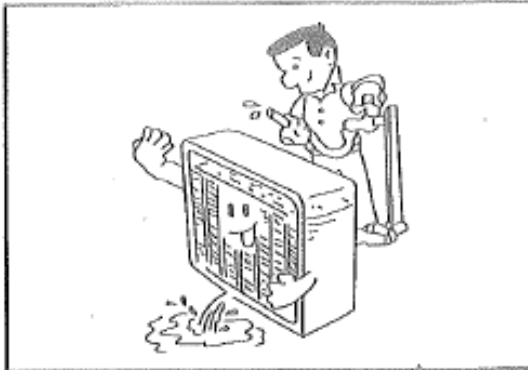
#### OPERATION AND CARE IN WINTER

##### Use of antifreeze (ethylene glycol base)

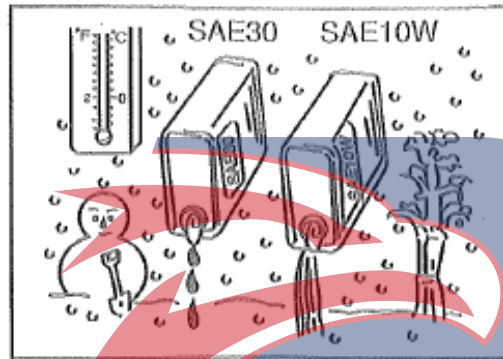
When the vehicle is parked in cold seasons or when you park the vehicle in a cold place, ensure the antifreeze performance of the engine coolant.

1. The appropriate mixing ratio of antifreeze can be determined in accordance with the curves shown in the figure above. It is the responsibility of the user to use the appropriate amount of anti-freezing agent according to the outside air temperature in the area of the vehicle.

# POWERSTAR

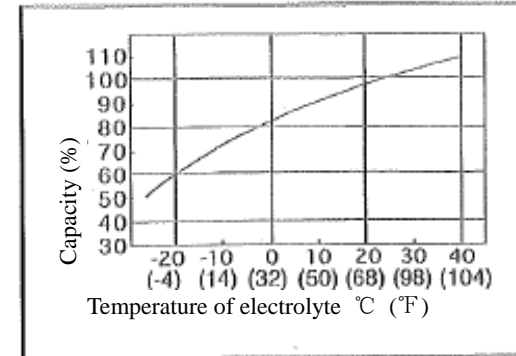


2. Prior to use of glycol-based antifreeze, it is best to flush the cooling system containing the radiator.
3. Damaged rubber hoses should be replaced because when the antifreeze is used, even the crack in the rubber hose is small, the engine coolant will leak out to the outside.



#### Engine oil

The engine oil thickens at lower temperature. Use engine oil with viscosity selected to suit the ambient temperature.



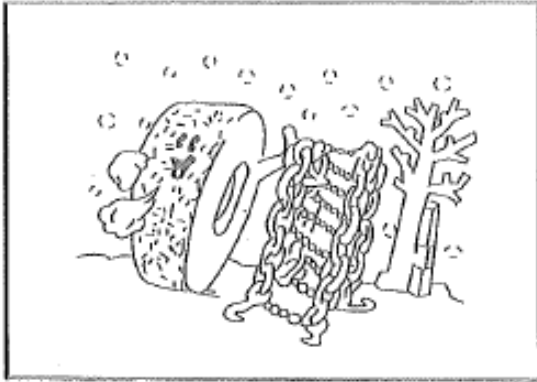
#### Batteries

The capacity of battery tends to decline with lowering temperature and specific gravity of the electrolyte lowers with rate of discharge.

Therefore, batteries should be protected against freezing.

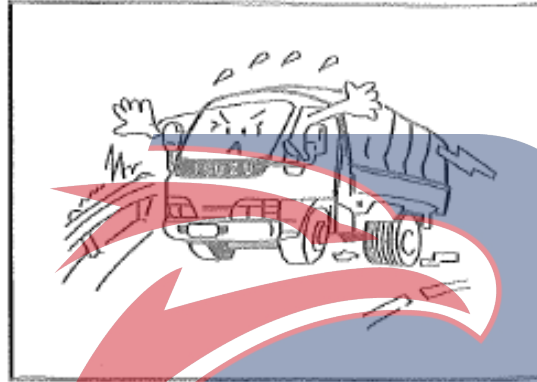
# POWERSTAR





### DRIVING ON ICE OR SNOW

1. The use of tire chains or snow tires is recommended.

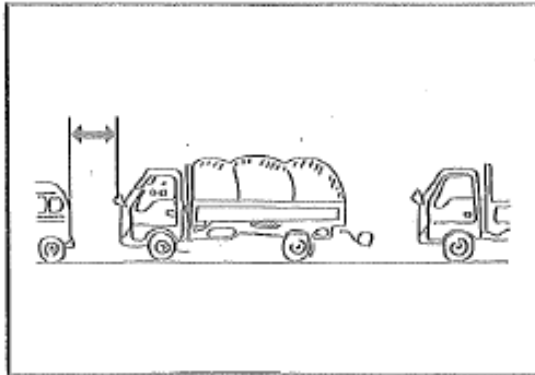


2. Avoid high speeds, hard acceleration, hard stops and sharp steering.

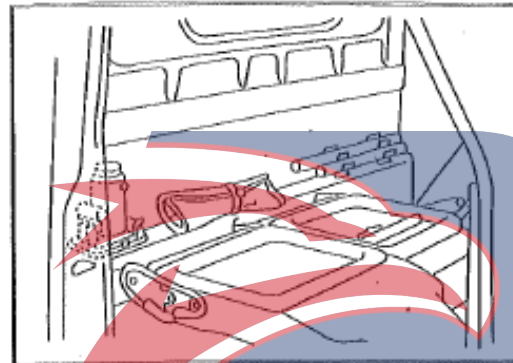


3. Use lower gear to gain retardation effect of the engine. Apply foot brake sparingly.

# POWERSTAR



4. Drive with a sufficient distance between you and vehicle ahead.

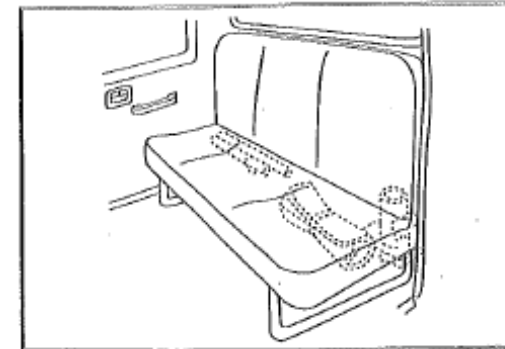


#### **IN CASE OF EMERGENCY**

##### **Storage of jacks and other tools**

##### **Vehicle model for the standard cab**

Common tools and jacks are stored behind the driver's seat. Always place them back in place and secure firmly to avoid impact noises during driving.



##### **Crew cab vehicle type**

The common tools and jacks are stored in the right lower side of the rear seat and they can be taken out after the soft seat cushion of the rear seat is raised. Always place them back in place and secure firmly to avoid impact noises during driving.

# POWERSTAR



## Overheating of the engine

If the engine is overheated.....

- The pointer of water temperature meter will point to the "(-)" position or higher than the "H" position.
- The "pop" sound of the engine becomes larger.
- The output power of the engine decreases.
- Steam or boiling water blow out from the radiator.

If you see this phenomenon, the engine is overheated.

when you stop the vehicle, but if you see or hear the steam or engine coolant from the engine compartment, do not open the engine at once to check the cover or tilt the cab, you should wait until you can't see the steam or engine coolant, then open the engine to check the cover or tilting the cab in order to provide a good ventilation.

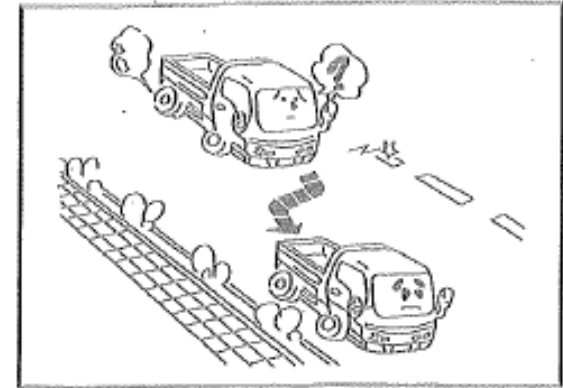
- Keep the engine running for 5-10 minutes, at a speed slamply higher than the idle speed (approx. 1500 rpm). If coolant leaks are present, stop the engine immediately.
- Stop the engine and allow the engine and the radiator to cool down.
- Carefully remove the cover of the radiator.

- Check the coolant level in the radiator when the engine is cool. If necessary, fill the coolant liquid into the radiator until the fluid level reaches the filler neck. And fill the coolant liquid level to the spare water tank until the level mark of the spare water tank.

### WARNING

- **To avoid scalding, do not remove the radiator cap when the engine and the radiator are still very hot. If the radiator cap is removed too quickly, the hot liquid and the steam will spray out outward and scald people under pressure.**

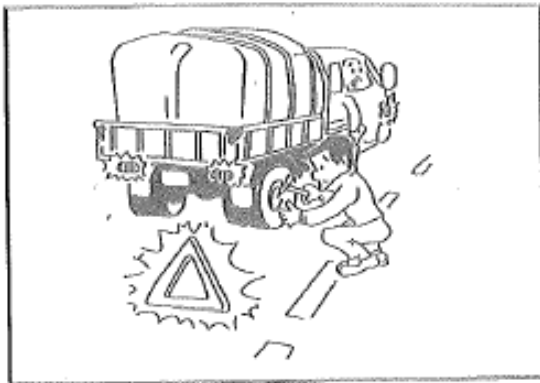
- **Glycol coolant in the engine is flammable under certain conditions. Therefore, do not splash it onto the hot parts of the exhaust system or the engine when this coolant is filled.**



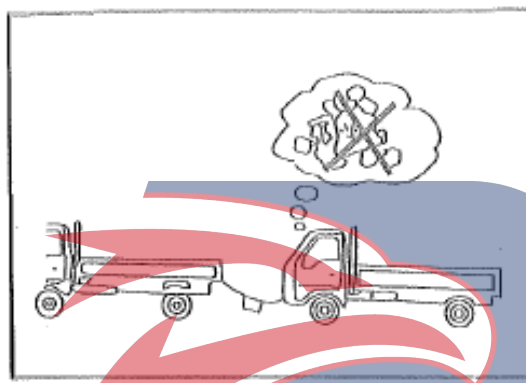
### Emergency stop

1. If you must stop your vehicle on the road for a while for some reason or other, pull your vehicle over to the right (or left) side of the road as far as possible and try not to park on the driving lane.

# POWERSTAR



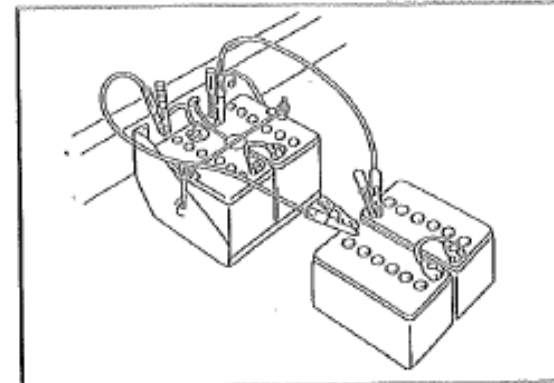
2. Be sure to apply the parking brake and use a hazard warning flasher, day or night.



### Emergency starting

#### **WARNING**

Never tow vehicle to start the engine because the surge forward when the engine starts could cause a collision with the towing vehicle.

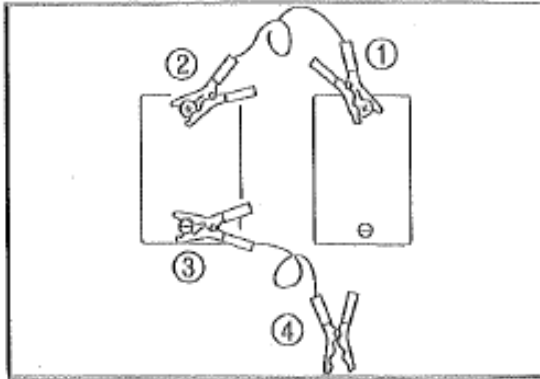


When the battery is discharged completely, it is possible to use the same (i.e. 12 volts) auxiliary battery that is the same as the rated voltage of the battery for starting the vehicle.

#### **WARNING**

Exercise extreme care when handling a battery to avoid serious personal injury which might result from battery explosion, acid burns, or electrical shock.

# POWERSTAR



#### Connecting procedures:

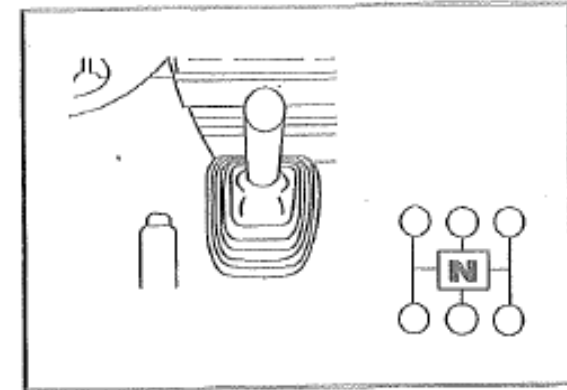
The engine can be started with another vehicle battery using the jumper cables.

1. Use the vehicle which has the battery of the same voltage (12 V).
2. Connect the jumper cables in the following sequence.
  - ① Positive terminal of the dead battery
  - ② Positive terminal of the booster battery
  - ③ Negative terminal of the booster battery
  - ④ Chassis ground of the dead battery's vehicle, where is as far as possible from dead battery.
3. After connecting the cables, start the engine of the booster battery's vehicle.

4. Raise the engine speed of the booster battery's vehicle slowly, then start the engine of the dead battery's vehicle.
5. After the engine is started, disconnect the cables in the reverse sequence of connection.

#### CAUTION

Never connect the cable between the positive and negative terminals. Do not remove the cables from the terminal posts while the engine is running, otherwise the fault in the electrical system may be caused.

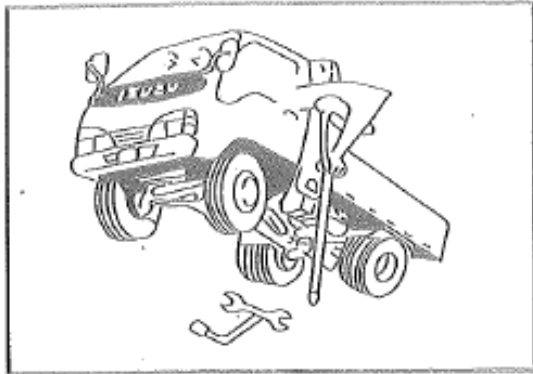


#### Towing

During traction to the vehicle that cannot be driven, pay attention to the following points:

1. If the transmission is in the normal operating state, place the shift lever in the NEUTRAL position.

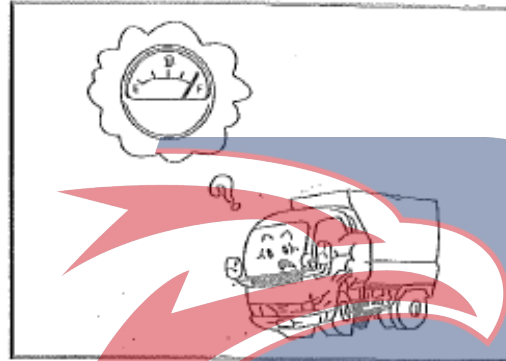
# POWERSTAR



2. If the transmission fails, remove the transmission shaft from the rear axle flange and fasten it to the frame.

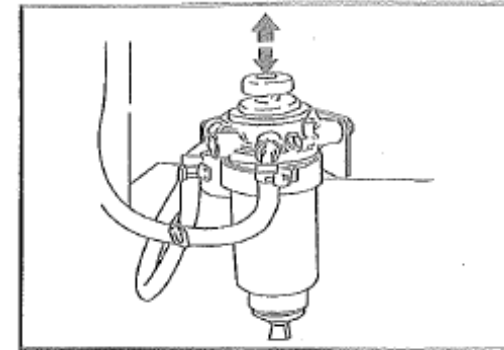
**CAUTION**

Then, put a towing rope (safety chains or cable) on the hooks provided on the tow vehicle and disabled vehicle. Traction shall be conducted at a speed of 40 km/ h, and the traction distance shall be less than 80 km.



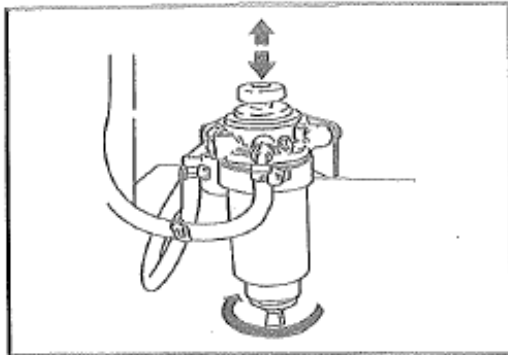
**Exhaust of the fuel system**

If the fuel in the fuel tank has been completely used up, the air is likely to enter the fuel system. If the air is sucked into the fuel system, the fuel is blocked and cannot flow into the engine smoothly. In order to prevent this phenomenon, the air fuel system must be exhausted.



1. Operate the manual pump mounted on the water separator so that the fuel contained in the fuel system is pumped into the fuel injection pump.
2. After the fuel system is exhausted, start the engine with the start switch.
3. If the engine does not start within 10 seconds, repeat Step 1 through Step 2.

**POWERSTAR**



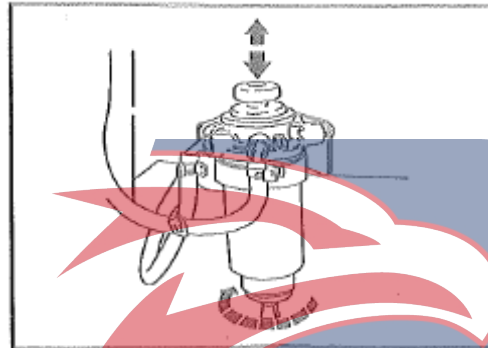
### Drain of oil-water separator

When the water indicator on the fuel filter is illuminated, drain the water immediately in accordance with the following procedure.

1. Find a safe place for parking the vehicle.
2. Open the hood of the engine and place the water container with a capacity of approx. 0.2 litres to the terminal of the ethylene hose connected to the drain cock of the water -separator.

### CAUTION

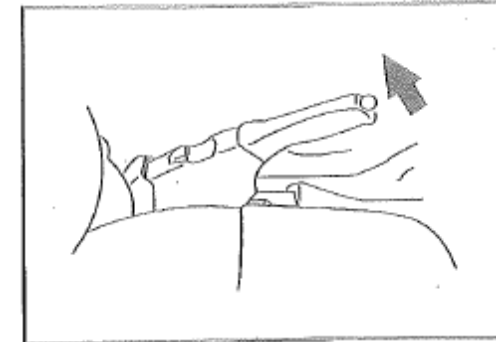
If drainage is required frequently, you can invite QingLing dealer (maintenance station) to drain the water in the fuel tank.



3. Loosen the drain cock in the counterclockwise direction and operate the starting oil priming pump for about 10 times, until the drainage is about 0.1 litres.

4. After draining, tighten the drain cock in a clockwise direction and operate several times of priming pump for several times.

5. After starting the engine, check that whether the fuel flows out of the drain cock through the drain cock or not. Also, it is required to check whether the fuel filter indicator is off or not.



Jacking instructions and changing a flat tire

### WARNING

To avoid personal injury:

Operate according to the Instruction of the lifting device and the equipment that are loaded.

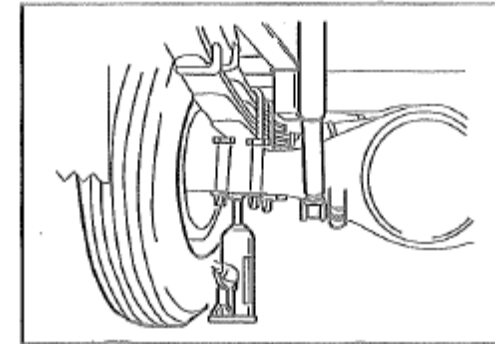
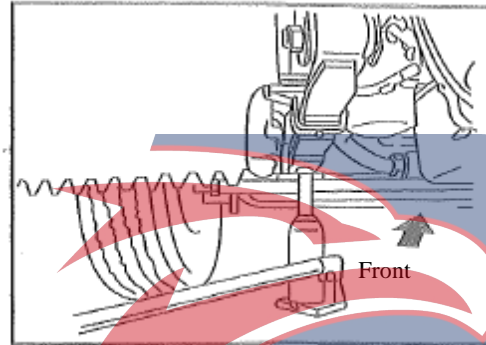
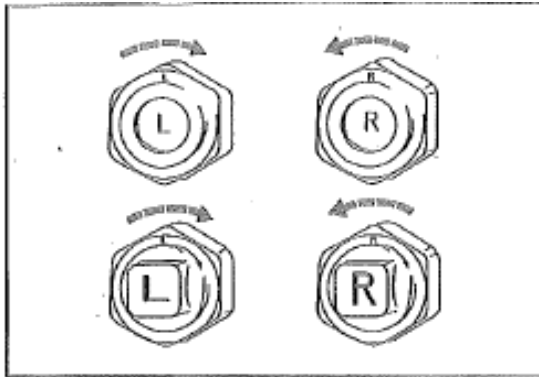
• Use a jack only when the vehicle is raised for replacing the wheels.

Never get under the vehicle when it is supported only by a jack.

The spare wheel (or inner wheel) and all lifting devices shall be properly kept at any time.

Do not start or run the engine when the vehicle is on the jack.

The jack must be placed on a solid plane.



### Preparation:

1. Park on level surface and set the parking brake or spring brake valve lever firmly.
2. Shift the shift lever into the "R" position.
3. Put the hazard indicator lamps in action.
4. Brace the wheels diagonally opposite the jacking position.
5. Loosen but do not remove wheel nuts.

### NOTE

The wheel nut for the right wheel is the right hand thread and the wheel nut for the left wheel is left-hand thread.

6. Put the jack on top of the fulcrum under the following rules

### CAUTION

•Do not jack up any points other than specified jack points.

### Front wheel:

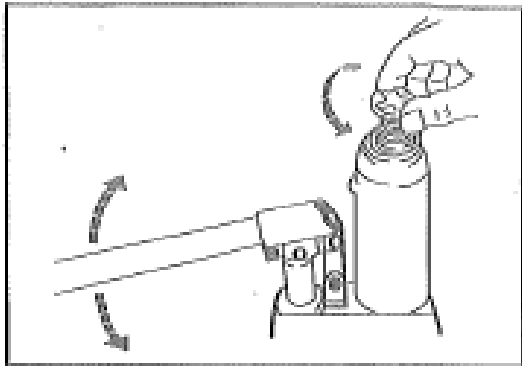
Place the jack under the leaf.

### Rear wheel:

Place the jack on the rear axle in the position of the spring steel plate.

# POWERSTAR



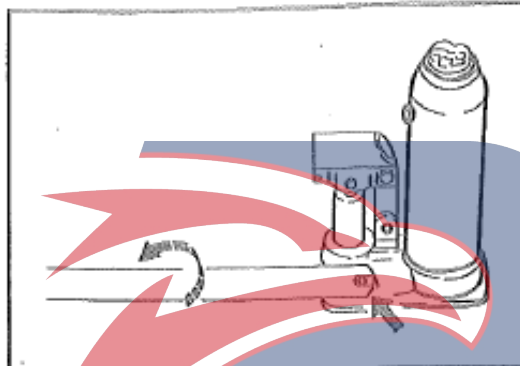


#### Usage of jack

##### To jack up:

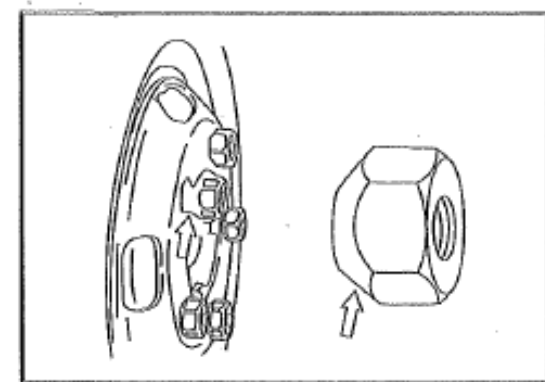
If the jack up point is high, extend the jack head by turning it counterclockwise.

Insert the jack bar as shown in the figure and move it up and down.



##### To lower:

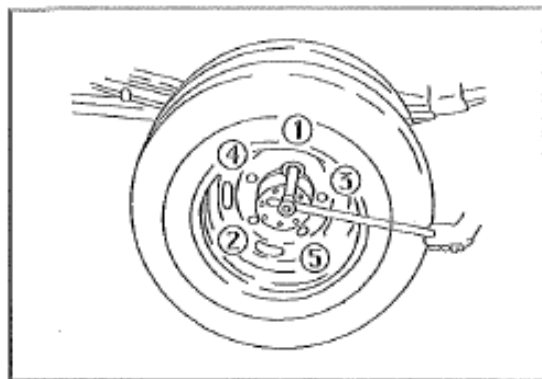
Slowly turn the bleeder screw counterclockwise with the jack bar as shown in the figure.



##### Wheel replacement:

1. Jack up the vehicle until the tire that needs to be replaced just leaves the ground, unscrew the wheel nuts, remove the wheel, and install the spare wheel.
2. Mount the wheel nuts with the tapered face toward the wheel. Then screw each wheel nut to a semi-locked state with a wheel wrench to seat the wheel nuts on the wheel hub. Unscrew the return oil hole screw counterclockwise in order to lower the vehicle to the ground.

# POWERSTAR



3. With the wheel wrench, tighten the wheel nuts in sequence as shown in the figure. Firmly lock all wheel nuts according to the following tightening torque.

Wheel nut torque N.m

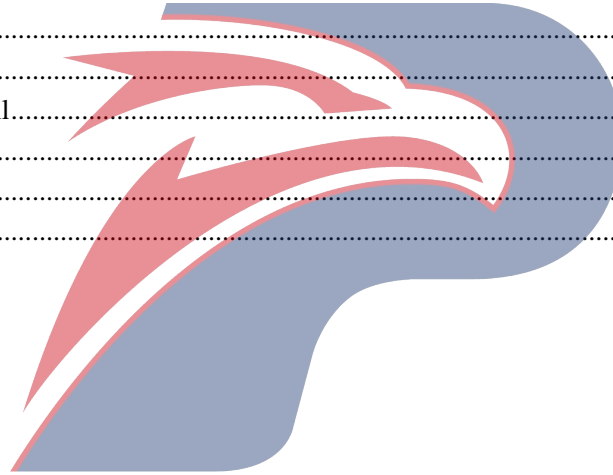
Rear single wheel model (QL * E *)	170
Rear double wheel model (QL * E, * QL * H *)	490

# POWERSTAR



## 5 SERVICE AND MAINTENANCE

Maintenance schedule .....	5-2
Maintenance guide .....	5-10
Lubrication .....	5-41
Recommended brand for lubricating grease and diesel oil.....	5-43
Lubrication chart .....	5-45
Lubrication guide .....	5-46
Forced ventilation system for crankcase (PVC) system.....	5-60



# POWERSTAR



## SERVICE AND MAINTENANCE

In order to maintain safety and economical operation, it is suggested that periodic inspection and maintenance should be performed regularly according to the recommendations outlines in this section.

### MAINTENANCE SCHEDULE

To insure driving safety and maximum economical operation, periodic inspection and maintenance should be performed at your authorized dealer according to the maintenance schedule.

For service operations which call for disassembly or specialized instruments, contact your authorized dealer.

### Maintenance operations

I: Inspect, clean up and repair or replace as necessary

A: Adjust

R: Replace

T: Tighten to specified torque

L: Lubricate

**When performing checks on the following items, regular inspection items should also be checked.**

\*Marks =Under severe driving conditions, more frequent maintenance is required. Refer to "Maintenance schedule under severe driving conditions".



# POWERSTAR



### Maintenance schedule

I: Inspect, clean up and repair or replace as necessary A: Adjust R: Replace T: Tighten to specified torque L: Lubricate

Use odometer reading or period, whichever comes first.

	Service interval: x 1,000KM		Service interval or month number																				
	1	5	10	15	20	25	30	35	40	45	50	55	60	65	70	75	80	85	90	95	100		
	x 1,000 miles		0.6	3	6	9	12	15	18	21	24	27	30	33	36	39	42	45	48	51	54	57	60
<b>ENGINE</b>																							
* Engine oil	-	R	R	R	R	R	R	R	R	R	R	R	R	R	R	R	R	R	R	R	R	R	R
*Engine oil filter	-	-	R	-	R	-	R	-	R	-	R	-	R	-	R	-	R	-	R	-	R	-	R
Fuel filter	-	-	-	-	R	-	-	-	R	-	-	-	R	-	-	-	R	-	-	-	R	-	-
*Air filter element	-	I	-	I	-	I	-	I	-	I	-	I	-	I	-	I	-	I	-	I	-	I	-
Idling speed and acceleration					I				I				I				I				I		
Valve clearances	I									A										A			
Loose or damaged connection of fuel tank cap and fuel pipe																							
Tension and damage of fan belt	I	-	I	-	I	-	I	-	I	-	I	-	I	-	I	-	I	-	I	-	I	-	I
Radiator Coolant (Antifreeze: Glycol Base)																							
* Damage or loosening of exhaust pipe and its mounting parts																							
Cooling system					I				I				I				I				I		
Engine operating condition	-		I		I		I		I		I		I		I		I		I		I		I





## Maintenance schedule

I: Inspect, clean up and repair or replace as necessary A: Adjust R: Replace T: Tighten to specified torque L: Lubricate

Use odometer reading or period, whichever comes first.

	Service interval: x 1,000KM		5	10	15	20	25	30	35	40	45	50	55	60	65	70	75	80	85	90	95	100	Service interval or month number
	x 1,000 miles		0.6	3	6	9	12	15	18	21	24	27	30	33	36	39	42	45	48	51	54	57	
<b>CLUTCH</b>																							
Clutch fluid	-	-	I	-	I	-	I	-	R	-	I	-	I	-	I	-	R	-	I	-	I	Every 24 months	
Clutch pedal free play and pedal stroke	-	I	I	I	I	I	I	I	I	I	I	I	I	I	I	I	I	I	I	I	I	I	Every 3 months
<b>TRANSMISSION</b>																							
* Hand-operated transmission oil			I		I		I		R		I		I		I		R		I		I	Every 24 months	
Looseness in gear control mechanism									I									I				Every 24 months	
Gear control cable					A				A					A				A				A	Every 12 months
<b>PROPELLER SHAFT</b>																							
*Universal joint and splines for wear					L				L					L				L				L	Every 12 months
Looseness in related parts			I		I		I		I		I		I		I		I		L		I	I	Every 6 months
Excessive spline wear									I									I					Every 24 months
Loose bearing and associated parts									I									I					Every 24 months
Intermediate bearing					L				L					L				L				L	Every 12 months
<b>REAR AXLE</b>																							
*Differential gear oil			I		I		I		R		I		I		I		R		I		I	Every 24 months	
<b>FRONT AXLE</b>																							
* Steering master pin			L		L		L		L		L		L		L		L		L		L	Every 6 months	
<b>STEERING</b>																							



**Maintenance schedule**

I: Inspect, clean up and repair or replace as necessary A: Adjust R: Replace T: Tighten to specified torque L: Lubricate

Use odometer reading or period, whichever comes first.

Service interval: x 1,000KM	1	5	10	15	20	25	30	35	40	45	50	55	60	65	70	75	80	85	90	95	100	Service interval or month number	
	x 1,000 miles	0.6	3	6	9	12	15	18	21	24	27	30	33	36	39	42	45	48	51	54	57		60
Steering gear oil							I						I						I				Every 18 months
Clearance between knuckle and front axle		-	I	-	I		I		I		I		I		I		I		I		I		Every 6 months
The steering mechanism is loose or damaged									I								I						Every 24 months
Clearance of steering wheel		I	I	I	I	I	I	I	I	I	I	I	I	I	I	I	I	I	I	I	I	I	Every 3 months
Steering Function		I	I	I	I	I	I	I	I	I	I	I	I	I	I	I	I	I	I	I	I	I	Every 3 months
Wheel alignment									I								I						Every 24 months

**POWERSTAR**

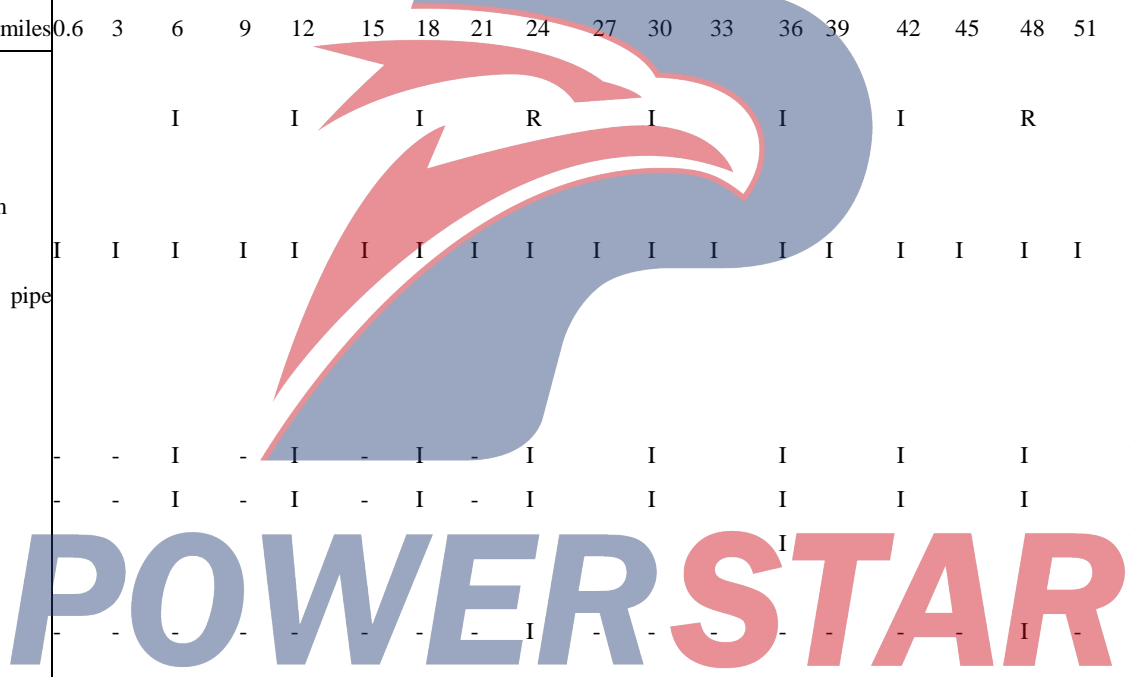


**Maintenance schedule**

I: Inspect, clean up and repair or replace as necessary A: Adjust R: Replace T: Tighten to specified torque L: Lubricate

Use odometer reading or period, whichever comes first.

	Service interval: x 1,000KM																						Service interval or month number		
	1	5	10	15	20	25	30	35	40	45	50	55	60	65	70	75	80	85	90	95	100				
	x 1,000 miles		0.6	3	6	9	12	15	18	21	24	27	30	33	36	39	42	45	48	51	54	57	60		
<b>SERVICE BRAKE</b>																									
Brake fluid			I		I		I		R		I		I		I		R		I		I				Every 24 months
Brake fluid leakage in the brake system																								I	Every 6 months
* Wear of friction lining and brake drum																								I	Every 12 months
Stroke and free stroke of plate making	I	I	I	I	I	I	I	I	I	I	I	I	I	I	I	I	I	I	I	I	I	I	I	I	Every 6 months
Loose or damaged connection of pipe clamps and hoses																								I	Every 6 months
<b>PARKING BRAKE</b>																									
Parking brake cable	-	-	I	-	I	-	I	-	I	-	I	-	I	-	I	-	I	-	I	-	I	-	I	-	Every 6 months
Function of the parking brake	-	-	I	-	I	-	I	-	I	-	I	-	I	-	I	-	I	-	I	-	I	-	I	-	Every 6 months
Stroke of parking brake lever																								I	Every 6 months
Wear of friction lining																									Every 24 months
Brake drum for wear and damage																								I	Every 24 months
Worn or damaged ratchet																									Every 24 months
<b>SUSPENSION</b>																									
Damage to the spring of the steel plate			I		I		I		I		I		I		I		I		I		I		I		Every 6 months







**Maintenance schedule**

I: Inspect, clean up and repair or replace as necessary A: Adjust R: Replace T: Tighten to specified torque L: Lubricate

Use odometer reading or period, whichever comes first.

	Service interval: x 1,000KM		1	5	10	15	20	25	30	35	40	45	50	55	60	65	70	75	80	85	90	95	100	Service interval or month number
	x 1,000 miles		0.6	3	6	9	12	15	18	21	24	27	30	33	36	39	42	45	48	51	54	57	60	
Mount for looseness and damage				I		I		I		I		I		I		I		I		I		I		Every 6 months
Shock absorbers for leaks			-	-	I	-	I	-	I	-	I	-	I	-	I	-	I	-	I	-	I	-	I	Every 6 months
Shock absorbers for looseness in mount				I		I		I		I		I		I		I		I		I		I		Every 6 months
<b>WHEELS</b>																								
Wheel pins (tire mounting bolts) and wheel nuts							T				T				T				T				T	Every 12 months
Damage to the tire steel ring							I				I				I				I				I	Every 12 months
Hub bearing grease											R								R					Every 24 months
Tire pressure and damage cup				I		I		I		I		I		I		I		I		I		I		Every 6 months
<b>ELECTRICAL EQUIPMENT</b>																								
Specific gravity of electrolyte				I		I		I		I		I		I		I		I		I		I		Every 6 months
Others																								

**POWERSTAR**

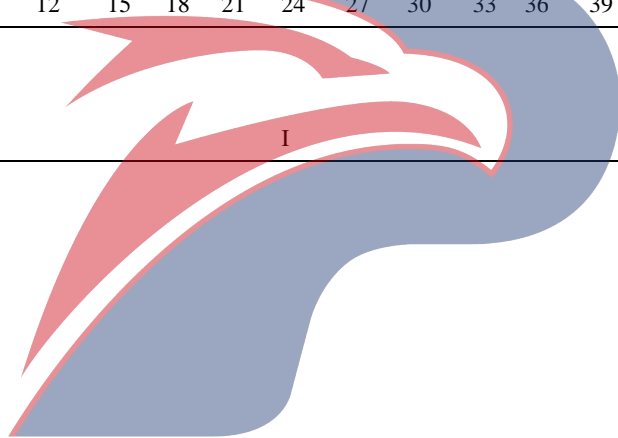


**Maintenance schedule**

I: Inspect, clean up and repair or replace as necessary A: Adjust R: Replace T: Tighten to specified torque L: Lubricate

Use odometer reading or period, whichever comes first.

	Service interval: x 1,000KM																			Service interval or month number				
	0.6	3	6	9	12	15	18	21	24	27	30	33	36	39	42	45	48	51	54		57	60		
Lamp, horn, windshield, wiper and washer																						I	Every 6 months	
Bolts and nuts on the frame and body																							I	Every 24 months



**POWERSTAR**



**Maintenance schedule under severe driving conditions**

Severe driving conditions

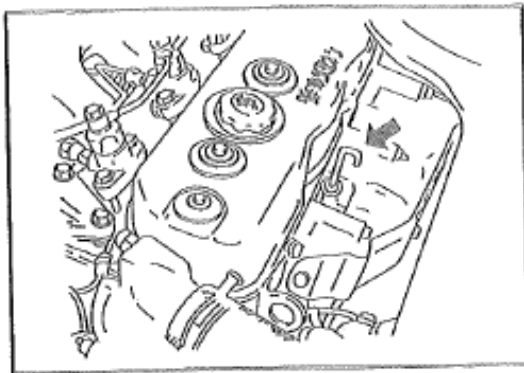
A: Repeated short trips

B: Driving on rough roads

C: Driving on dusty roads

D: Driving in extremely cold weather and/or on salted roads

Item	Interval	Condition				
		A	B	C	D	A+D
Engine oil	Replace every 2,500 km			•		•
Engine oil filter	Replace every 5,000 km			•		•
Exhaust pipes and	Replace every 10,000 km	•	•		•	
Air filter element	Replace every 20,000 km			•		
The steering mechanism is loose or damaged	Replace every 5,000 km		•			
Grease for universal joint and sliding sleeve	Replace every 10,000 km		•			
Manual Transmission Manual transmission and	Replace every 20,000 km					
Brake friction lining and brake drum is worn	Replace every 10,000 km	•	•	•		

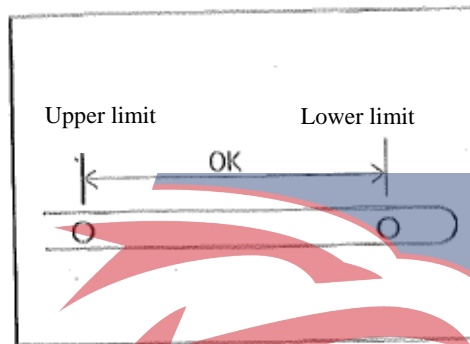


## MAINTENANCE GUIDE

### ROUTINE INSPECTION

#### Engine oil level

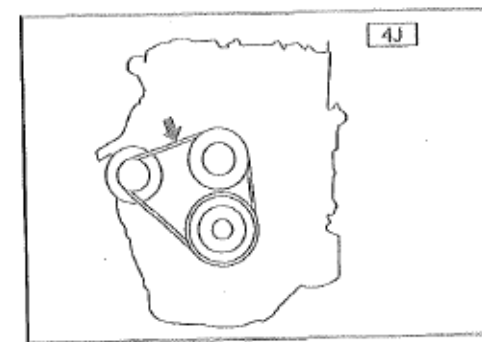
Pull out the oil level gauge rod (oil dipstick), wipe and clean it, and reinsert it. Again pull it out and check that the oil level is within the high and low level marks. Also check the oil on the gauge rod for contamination.



#### NOTE

**Engine oil level should be checked with the vehicle standing on level ground (before the operation of engine). And the engine should be stopped.**

**If the engine is running, stop the engine and allow 5 minutes for the oil to settle down before checking the oil level.**



#### Fan belt

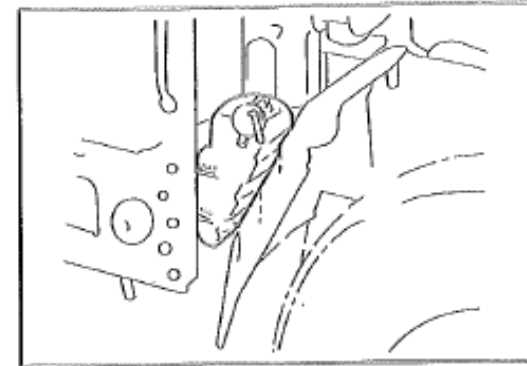
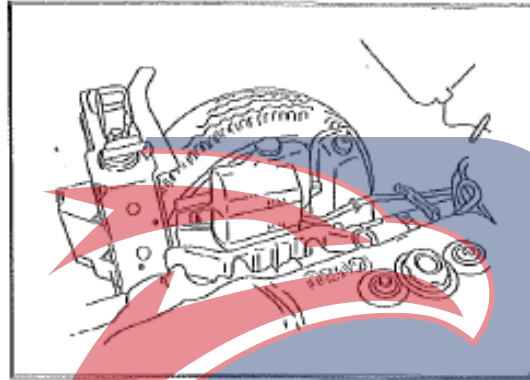
Press the middle section of the belt with a finger (press the force of 100 N,) to check that the deflection of the wind belt is within 8-12 mm.

Also check the belt for cracks and damage.

#### CAUTION

**If the tension of the belt is too small, it can cause insufficient charging of the battery or overheating of the engine, and the tension of the belt may cause damage to the alternator or the triangle belt.**

# POWERSTAR



**CAUTION**

**The fan belt should be checked. If the fan belt is broken, the brake booster will not act.**

**Coolant level**

Overheating of the engine may cause the engine to be faulty or damaged. In order to avoid these phenomena, the coolant level must be checked regularly.

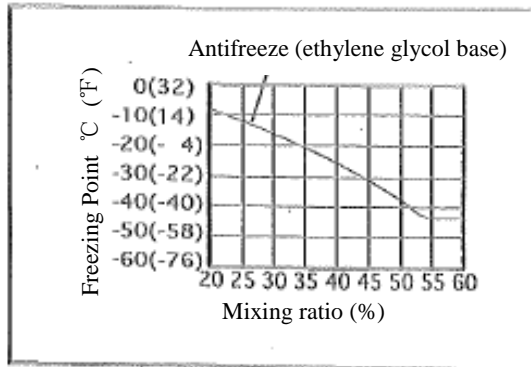
Check the coolant amount when the engine is cold; if necessary, supplement the coolant to the spare water tank of the radiator; if the liquid level in the standby tank is lower than the "Min" (lower limit), check the cooling system for leakage, and then add the coolant to "MAX" (Upper) scribed line.

**CAUTION**

**\* Attention shall be paid to avoid spillage of cooling liquid from the spare water tank.**

- If necessary, do not remove the water injection cover of the radiator.
- The coolant level should be checked after the engine is cooled down.
- The anti-corrosive agents or additives to increase the cooling effect that are not identified by used by QingLing Motors shall not be used in the cooling system. The cooling system shall not be used in the cooling system without the qualification of the QingLing Motors to increase the cooling effect.
- Add antifreeze corresponding to the outside air temperature in the area where the vehicle is used to prevent freezing of cooling water, which is to be taken by the user.
- Do not use water from wells or rivers as the coolant. If the specified grade of coolant cannot be purchased, the city tap water may be temporarily replaced.

POWERSTAR

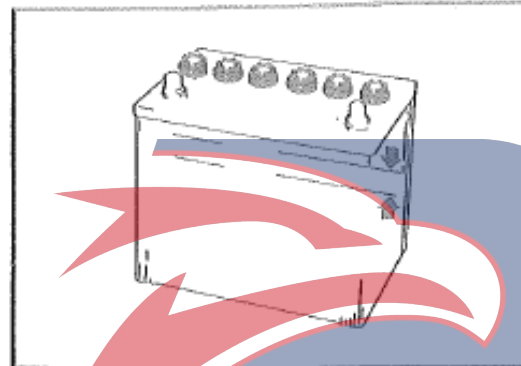


- When the cooling water is recharged and replaced, the engine coolant specified by QingLing Company shall be used.

Other brands of coolants tend to be free of corrosion inhibitor and may cause corrosion to the engine and the radiator.

- If the concentration of the engine coolant exceeds 60%, the specific heat characteristic will decrease, which may cause overheating of the engine, and in addition, if the concentration drops below 20%, the corrosion resistance will be reduced. Therefore, the coolant concentration shall be adjusted to a range of 20% to 60% depending on the specific conditions.

- Do not step on the radiator cap.



#### Level of battery electrolyte

If the fluid level of the battery electrolyte reaches its injection oval hole, it is normal. If the fluid level is too low, add distilled water. The battery is installed in the battery compartment on the left side of the rear floor of the front seat.

#### WARNING

The electrolyte in the battery is dilute sulfuric acid. This is a hazardous liquid to human body, so attention shall be paid not to burn skin or burn clothes, especially to prevent it from splashing into eyes. If the battery electrolyte is splashed into the eyes, rinse the electrolyte immediately with a large amount of clean water, and then consult a doctor.



#### Level of battery electrolyte

Check the amount of the steering wheel play by turning the wheel in both directions until the tires begin to move.

Standard play shall be within the following ranges.

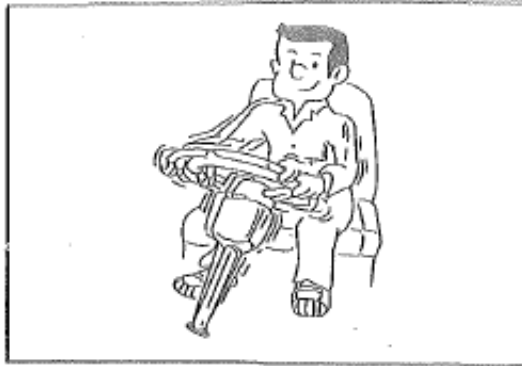
Manual steering mechanism: 10-30 mm

OPT Power steering mechanism: 10-50 mm

At this time, the play should be measured along the periphery of the steering wheel in the forward direction of the front wheels.

#### NOTE

If the vehicle is equipped with a power steering mechanism, The wheel free play must be checked with the engine running.

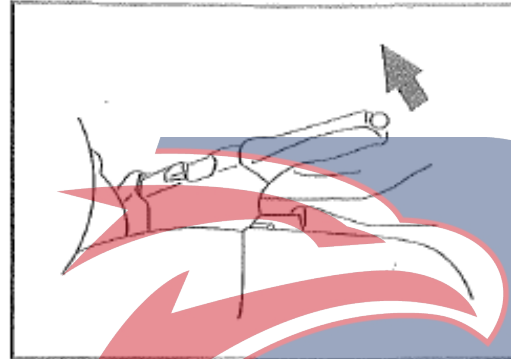


Also check the steering wheel for play and looseness in mount by moving it back and forth and sideways.

While driving check for hard-steering, steering shimmy and tendency of steering to pull to one side.

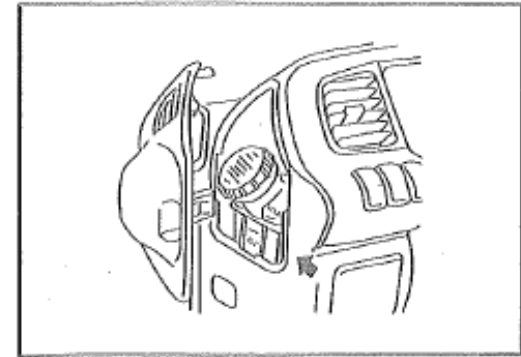
**CAUTION**

**If the steering mechanism components play is too large. In case of looseness and other abnormalities, the steering mechanism shall be checked by the QingLing Motors Special Distribution Shop (Maintenance Station).**



**Brake pedal free play**

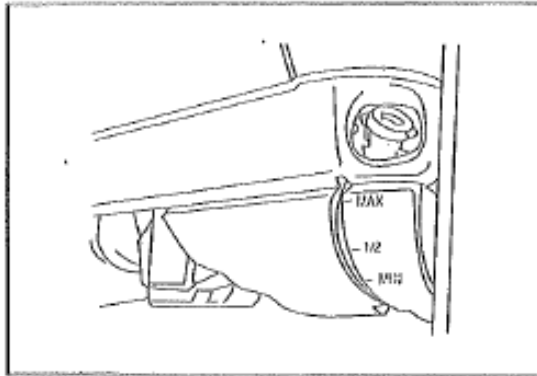
When the parking brake lever is pulled up by 150 N, its normal travel is 5 to 8 teeth. If its stroke exceeds 16 teeth, the brake action is insufficient and the brake adjustment is required.



**Brake fluid level**

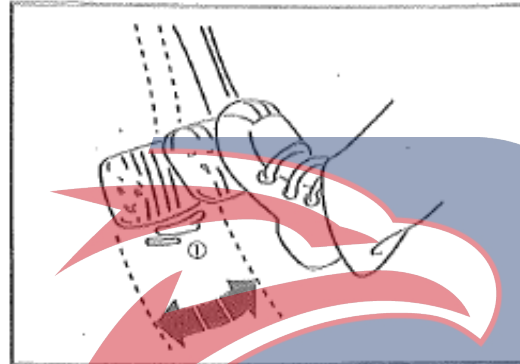
Check that the fluid level of the brake fluid is between the "MAX" and "ADD" level mark on the tank. If the level is lower than the "ADD" mark line, the recommended brake fluid should be added.

**POWERSTAR**



#### Windshield washer solution level

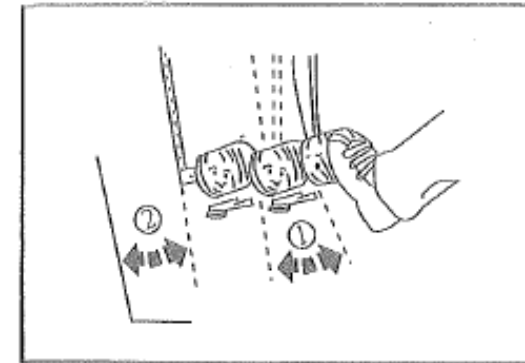
Check that the washer tank is filled sufficiently with solution. Also, check the windshield washer for proper operation.



#### Clutch pedal free play and stroke

**Standard value:**

- ① Free stroke: 15-25 mm



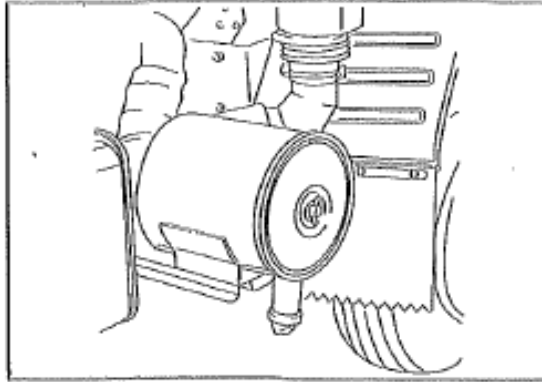
#### Free stroke and margin of brake pedal:

**Standard value:**

- ② Free stroke: 4-7mm
- ② Allowance: 40 mm

# POWERSTAR





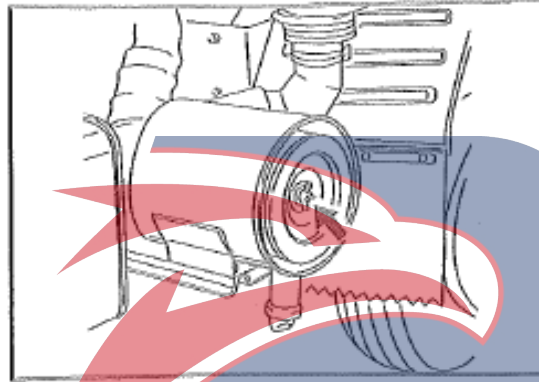
## PERIODIC MAINTENANCE

### Air filter

The use of fouled air filter element not only causes a deterioration in engine output, but also raises fuel consumption and generates dark exhaust smoke. Therefore, the air filter shall be maintained in accordance with the following methods.

#### NOTE

When replacing the filter element, you must use the air filter element specified by QingLing Motors.

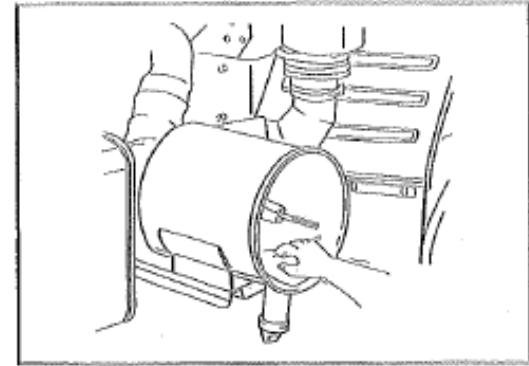


### 1. Remove the filter element (behind the cab)

- Loosen the wing nut and take out the filter element.
- Unscrew the wing nut securing the filter element and take out the filter element.

#### CAUTION

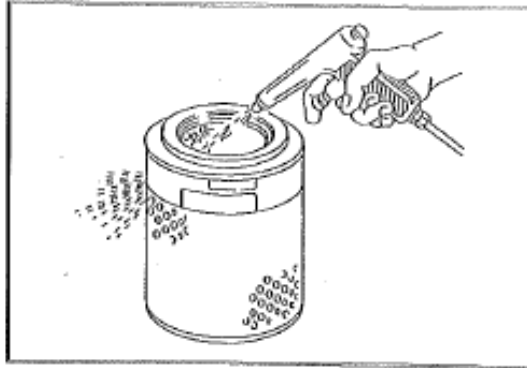
Handle the element carefully so as not to damage it.



### 2. Cleaning of air filter housing and cover

Wipe the dust on the inside of the air filter housing, the outer cover, and the gasket surface.

# POWERSTAR



### 3. Cleaning

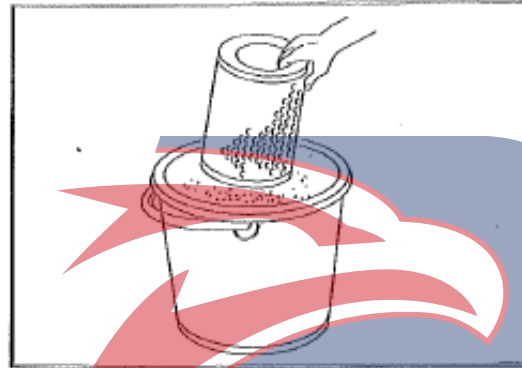
The element may be cleaned by either of the following steps described below depending on fouling conditions.

When the element is fouled but dry:

Turn the filter element by hand, and blow away the dust from the inside of the filter element with compressed air. The pressure of compressed air shall be less than 700 kPa.

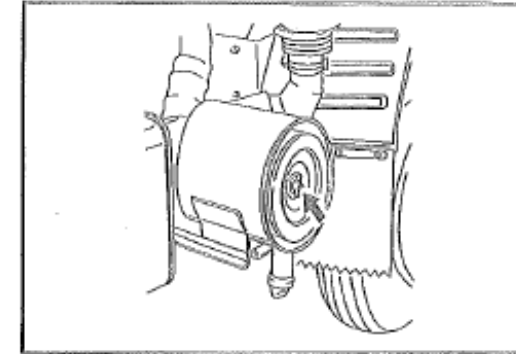
**NOTE**

Do not apply compressed air to the outer face of the element as it causes the dust to cling to the inner face (clean side) of it.



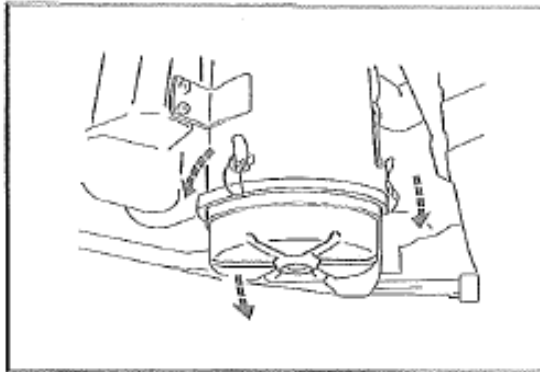
### When the element is fouled with carbon and oil:

1. Dilute the filter element cleaner (ISUZU element cleaner: Donaldson NDI500 or D1500) to prepare the cleaning solution. Immerse the filter element for approximately 20 minutes.

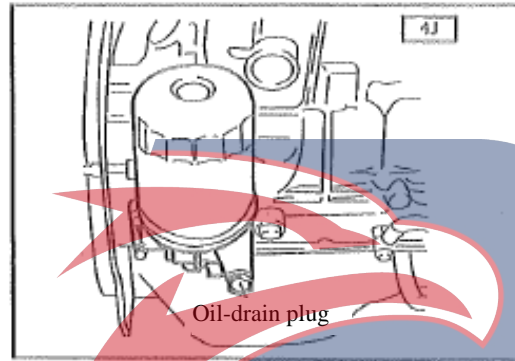


2. Take out the filter element and wash thoroughly with water. Water pressure shall not exceed 280 kPa.

# POWERSTAR

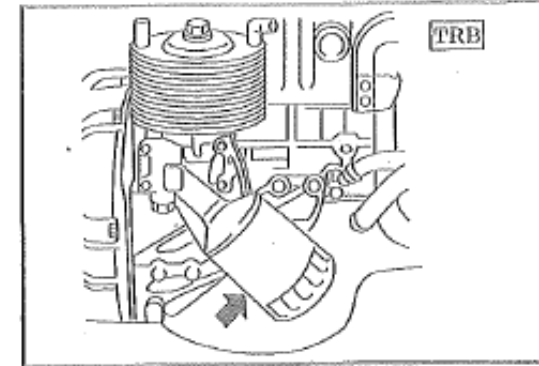


3. Rotate the filter element in a well-ventilated place to dry it. The fan can be used for drying the filter quickly. However, the filter cannot be dried by compressed air or fire to shorten the drying time. Because the filter element naturally dries normally for two days, it is better to use a spare filter.



#### **Main oil filter**

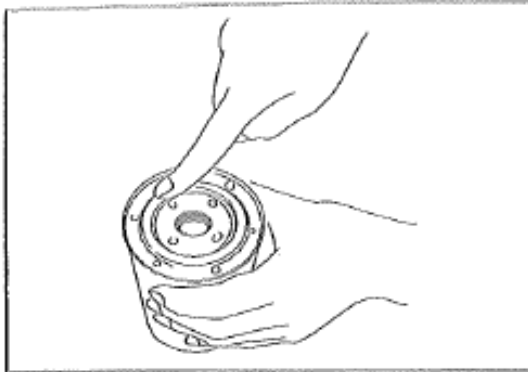
1. Loosen the drain plug (if equipped) that is located on the bottom of the oil filter to drain the oil.



2. Screw the oil filter with the oil filter wrench in the opposite direction to make it loose.

3. Wipe the mating surface of the oil filter bottom cover with a leftover of cloth so that the new oil filter can be properly installed on the mating surface.

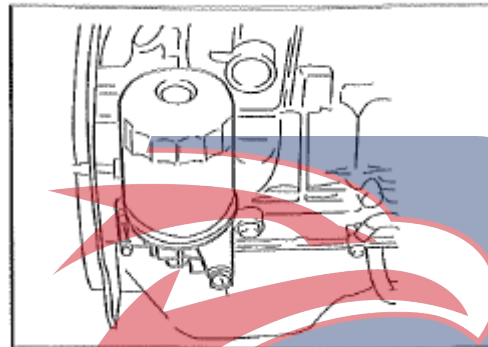
# POWERSTAR



4. Apply a coat of engine oil to the O-ring surface, fit the O-ring and slowly tighten the oil filter until the O-ring snugs against the sealing surface. Then, use the oil filter wrench to further tighten the oil filter to 3/4 turns.

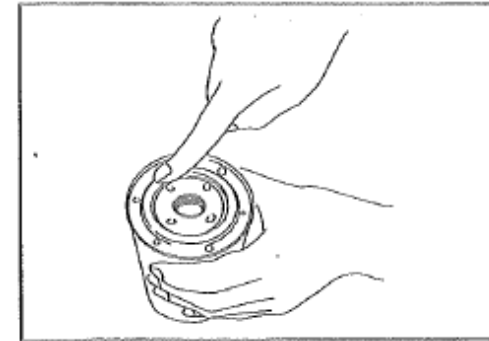
**CAUTION**

Check the oil level in the engine, if necessary, fill it to the specified oil level. Start the engine and check whether the oil filter is leaking or not. Always use the complete set of oil filter elements as specified by QingLing Motors when replacing.



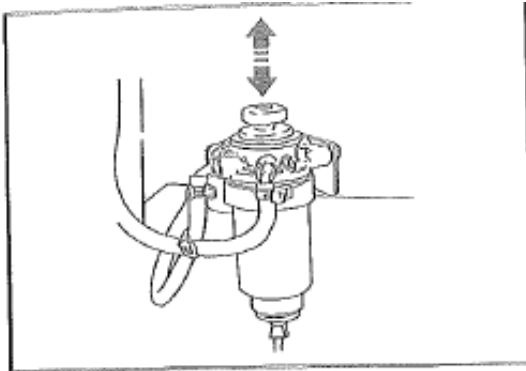
**Fuel filter**

1. Turn the filter in the counterclockwise direction with wrench of filter to loosen it.
2. Clean the mating surface of the filter holder head with a piece cloth, so that the new filter can be properly installed on the mating surface.

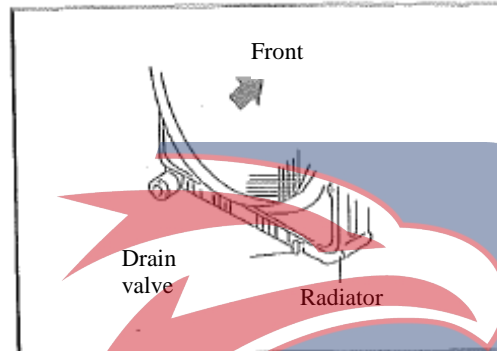


3. Apply a layer of engine oil to the O-ring surface. Install O-ring, on one hand, take care to avoid fuel spillage, on the other hand, turn the filter slowly towards the clockwise direction until the O-ring snugs against the sealing surface. Then, tighten the filter with a filter wrench to further tighten the filter for 2/3 turns.

**POWERSTAR**



4. Operate the priming pump on the oil-water separator several times in order to exhaust the fuel system.
5. After the fuel filter has been exhausted, start the engine with the start switch.
6. If the engine fails to start within 10 seconds, the exhaust operation shall be carried out again.

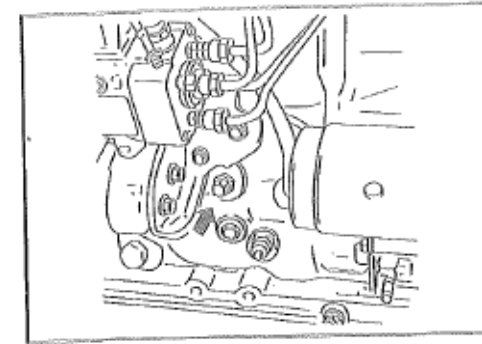


#### **Engine coolant**

To replace the engine coolant, loosen the drain valve on the radiator and cylinder body to drain the liquid in the cooling system.

The cooling system of the engine shall be flushed at least once a year to ensure optimum cooling effect.

QingLing Motors recommends to use the long-acting coolant (ethylene glycol base) that does not contain any rust inhibitor and other additives.

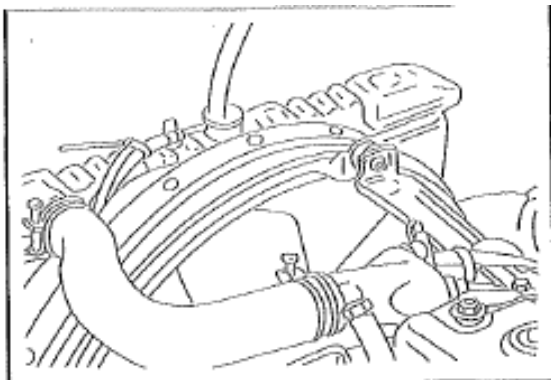


#### **CAUTION**

**When replacing or filling the coolant for the engine cooling system, the incorrect filling sometimes causes the coolant to overflow from the neck of the injection port under the state that the engine and the radiator are not full.**

**If the engine is running in this condition, insufficient coolant may cause overheating of the engine. To avoid this problem, always follow the following precautions when filling the coolant.**

# POWERSTAR

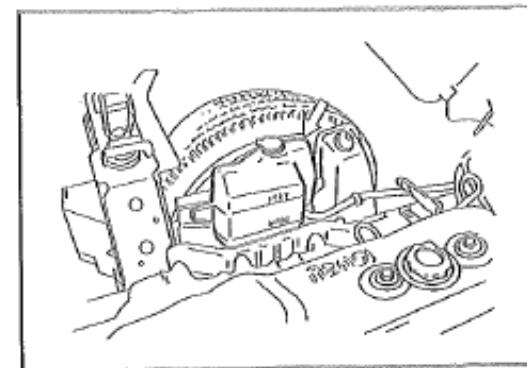


1. Use a filling hose with an outside diameter less than the inner diameter of the water injection neck. Otherwise, the ventilation space between the neck and the filler hose will be blocked to prevent the full topping up of the cooling system.

2. Maintain the filling rate of 9 L/ min or less. If the filling rate exceeds this maximum rate, the air in the engine radiator may not be completely discharged.

Also, even if the coolant overflows, it is difficult to verify that the system is fully filled.

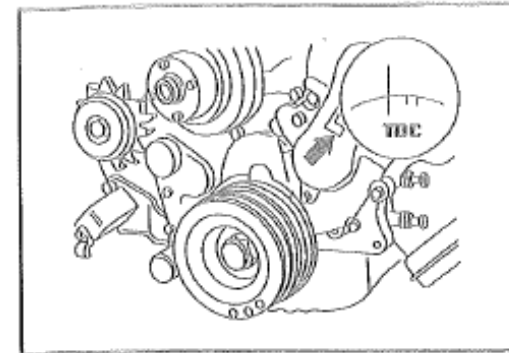
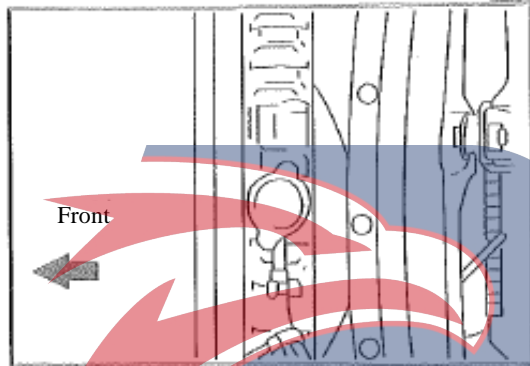
3. When the system is filled, take out the filling hose and check whether there is leakage of air bubbles in the system and whether the coolant level drops. If the fluid level drops, continue filling the coolant until the coolant surface is no longer lowered.



4. After filling the cooling system completely, fill the coolant to the spare water tank to maximum liquid level.



# POWERSTAR

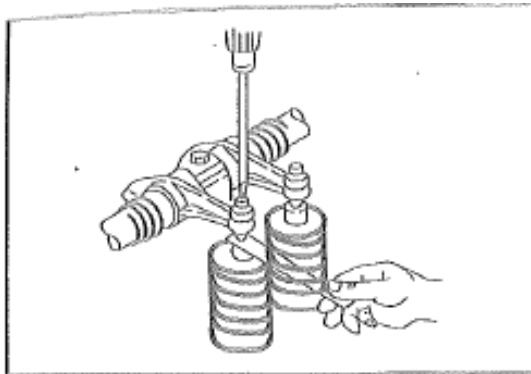


5. Install the water injection cover and tighten it (be sure to tighten the cover to the locking position) and then start the engine so that the water temperature rises to the temperature at which the thermostat valve can be opened (until the water temperature meter pointer points the temperature above the middle scale of the dial). Stop the engine and wait until the cooling water temperature drops, open the water injection  cap, and recheck the coolant level again. The level of the standby tank must also be checked too. If the fluid level is found to be insufficient, fill the coolant to the cooling system and/or the spare tank to the required level.

#### Valve clearance adjustment

1. Rotate the crankshaft until the top-deadcenter (TDC) line on the crankshaft pulley damper is aligned with the timing pointer. Move the piston in the cylinders 1 or, 4 to the top dead center of the compression stroke.

POWER STAR

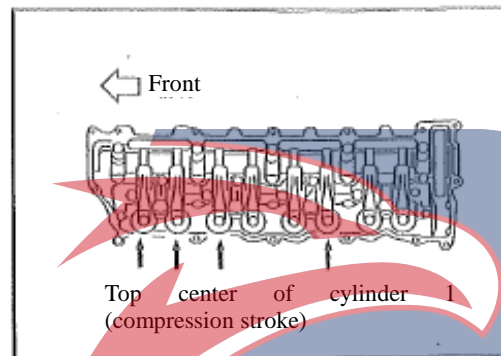


2. Use a feeler gauge to adjust the valve clearance.:

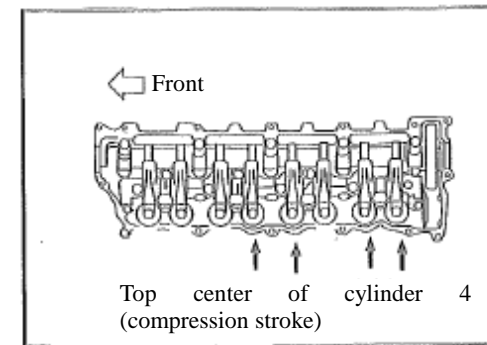
Valve clearance (Cold)

Intake: 0.4mm

Exhaus: 0.4mm



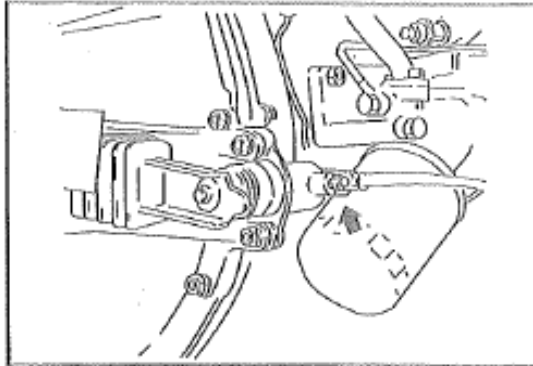
3. Adjust the valve lash as shown in the arrow first.



4. Rotate the crankshaft by one circle (360 degrees) and continue to adjust the valve lash shown in the arrow.

# POWERSTAR

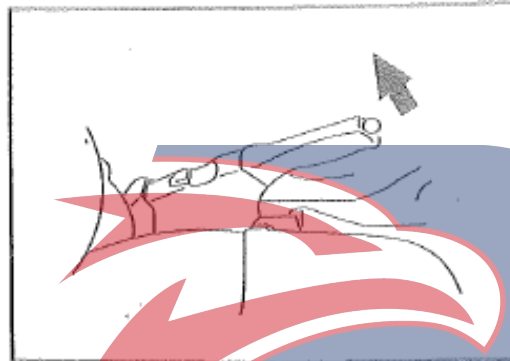




### **Bleeding of brake hydraulic circuit**

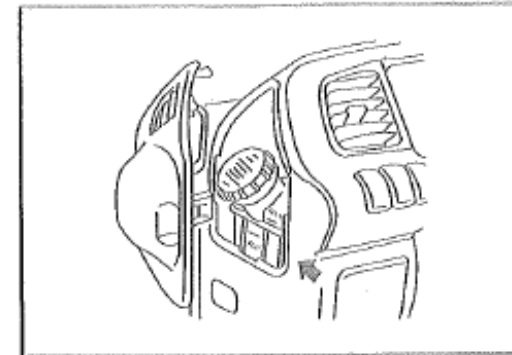
If air enters the brake hydraulic circuit it causes poor brake action. Therefore, bleeding operation should be performed if the brakes have been used with the brake fluid level in the reservoir lowered excessively or if the brake pipes have been disconnected in the course of brake servicing.

Bleeding operation calls for cooperative action of two men.



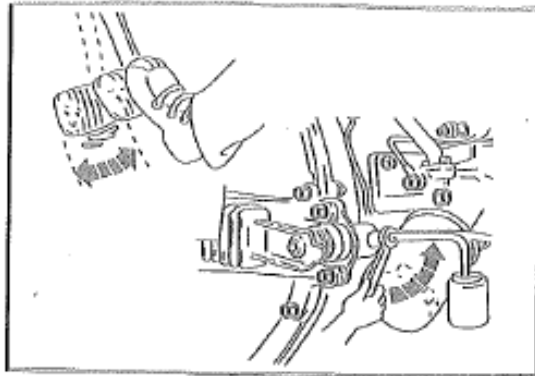
### **Follow these steps to bleed:**

1. Tighten the parking brake.



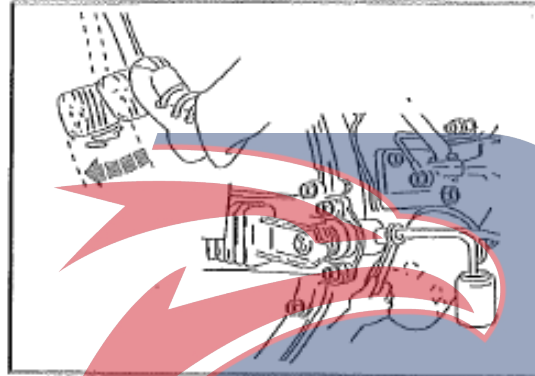
2. Check the liquid level of brake fluid and fill in if necessary.

# POWERSTAR



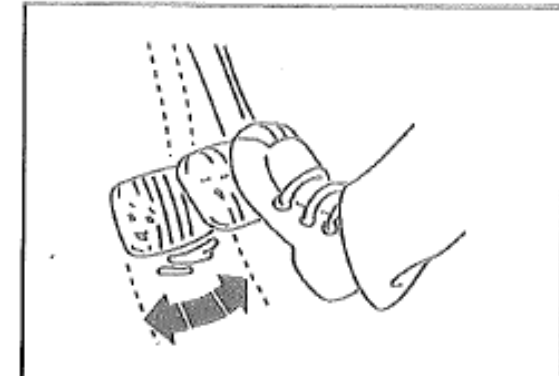
3. Remove the rubber cap from the bleeder screw and wipe clean the bleeder screw. Connect a vinyl tube to the bleeder screw and insert the other end of the vinyl tube into a transparent container.

4. Pump the brake pedal repeatedly and hold it depressed.



5. Loosen the bleeder screw to release the brake fluid with air bubbles into the container and tighten the bleeder screw immediately.

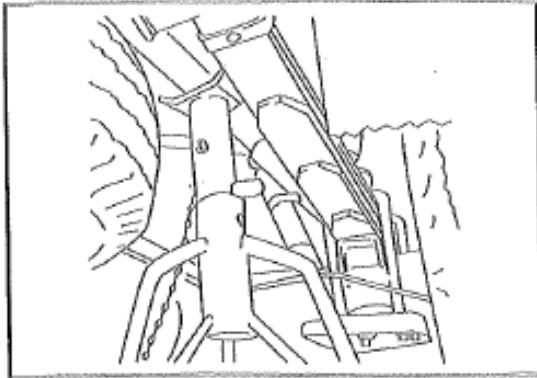
6. Release the brake pedal carefully. Repeat the above operation until the air bubbles disappear from the brake fluid by being pumped out into the container. During the bleeding operation, keep the brake fluid reservoir filled to the specified level. And place the rubber cap back.



#### **Main brake adjustment**

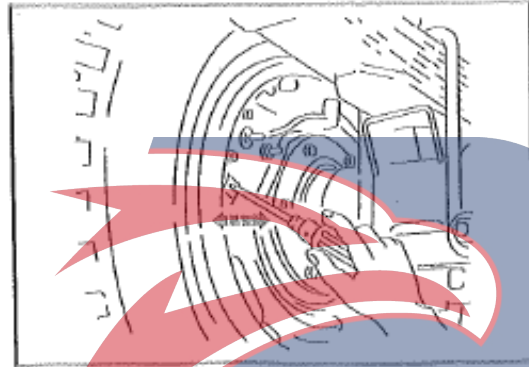
The brake system with excessive brake friction plate clearance is unsafe because the performance of the brake system decreases with the increased clearance between the friction plates. The clearance of the brake friction sheet shall be checked and adjusted regularly according to the specified period.

# POWERSTAR



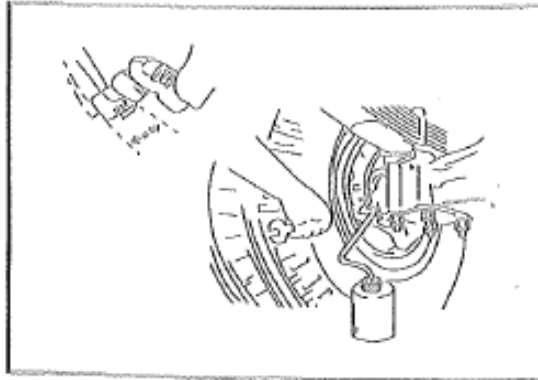
Adjust the front and rear wheel brake according to the following methods:

1. Jack up the wheel so that it leaves the ground completely.
2. Then pad into a secure support.
3. Remove the rubber plug from the brake adjustment hole on both sides of the front and rear of the brake rear panel.
4. Insert a screwdriver into the adjusting hole and turn the pinion to the direction shown in the arrow until the wheel is braked.



5. Turn the adjuster back to 5-6 teeth.
6. Reinstall the rubber plug.
7. Continue to adjust the brakes on other wheels according to the above adjustment procedure.

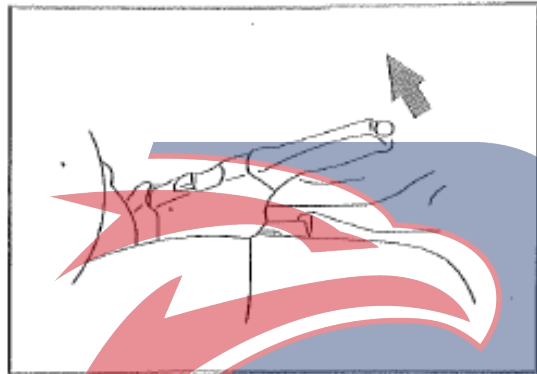
# POWERSTAR



### Bleeding of brake hydraulic circuit

If air enters the brake hydraulic circuit it causes poor brake action. Therefore, bleeding operation should be performed if the brakes have been used with the brake fluid level in the reservoir lowered excessively or if the brake pipes have been disconnected in the course of brake servicing.

Bleeding operation calls for cooperative action of two men.

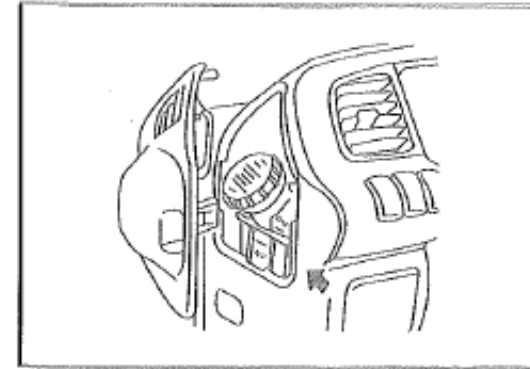


### To bleed, proceed as follows:

1. Tighten the parking brake.
2. Start and keep the engine running until the vacuum is fully raised.

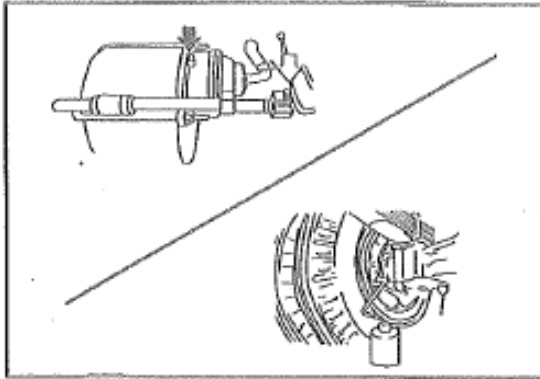
### CAUTION

**If the engine is not running, and the exhausting is conducted, poor effect may be caused to the brake booster (vacuum booster or hydraulic vacuum booster).**



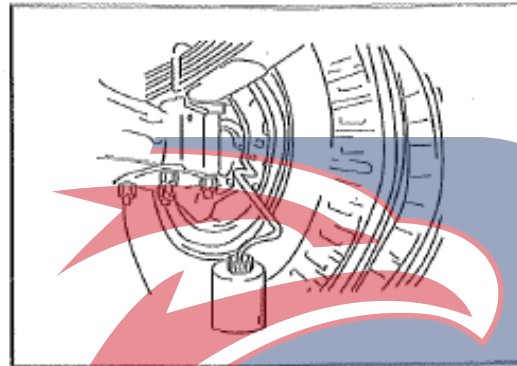
3. Check the liquid level in the brake fluid tank, if necessary, make a supplement;

# POWERSTAR

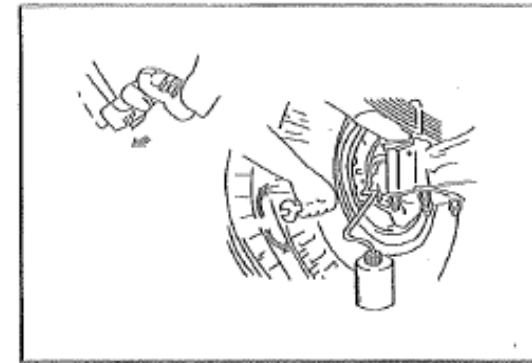


4. Exhaust the brake hydraulic circuit according to the following procedure.

Right rear wheel → deceleration sensing proportional valve (if equipped) → right front wheel → left front wheel → hydraulic vacuum booster (if equipped)



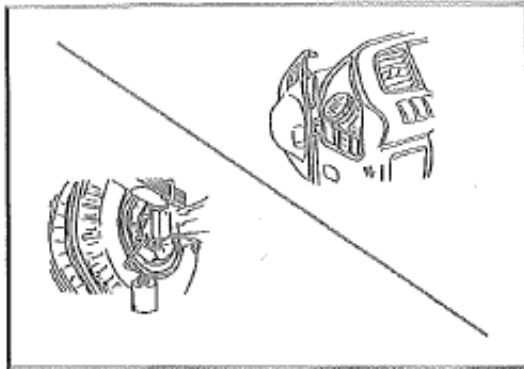
5. Remove the rubber cap from the bleeder screw and wipe clean the bleeder screw. Connect a vinyl tube to the bleeder screw and insert the other end of the vinyl tube into a transparent container.



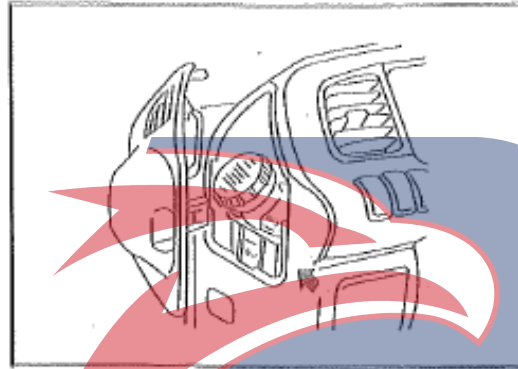
6. Pump the brake pedal repeatedly and hold it depressed.

Loosen the bleeder screw to release the brake fluid with air bubbles into the container and tighten the bleeder screw immediately.

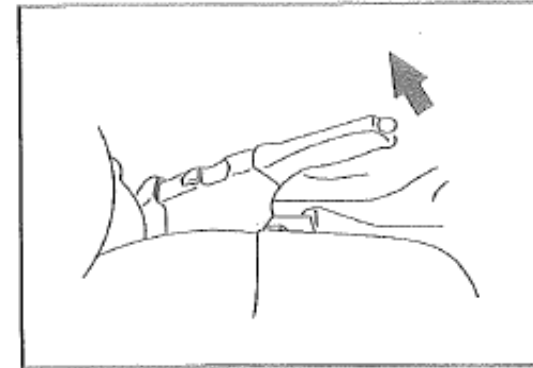
# POWERSTAR



7. Release the brake pedal carefully. Repeat the above operation until the air bubbles disappear from the brake fluid by being pumped out into the container. During the bleeding operation, keep the brake fluid reservoir filled to the specified level. And place the rubber cap back.



8. After exhausting each wheel, check the liquid level in the brake fluid tank, if necessary, make supplemental fill.

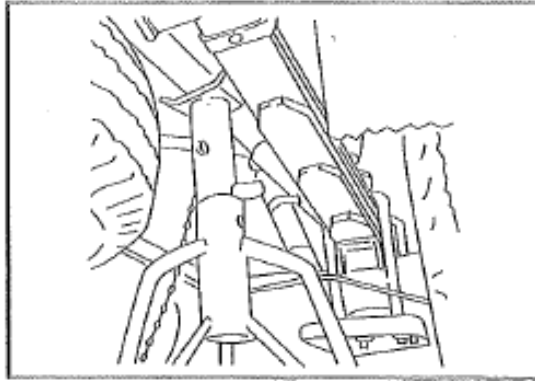


#### **Parking brake adjustment**

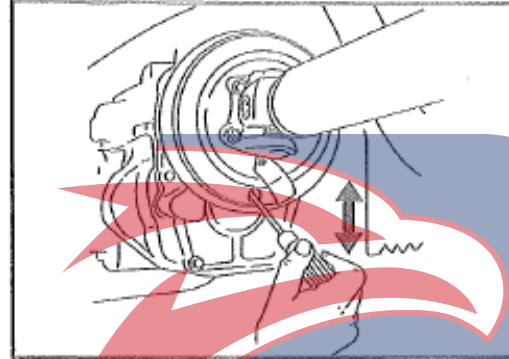
When the parking brake is applied with a force of 150N, if the parking brake lever is moved within the range of 5 ~ 8 teeth, its stroke should be normal. The parking brake should be adjusted by with this method:

1. Brace the front wheels and fully release the parking brake.

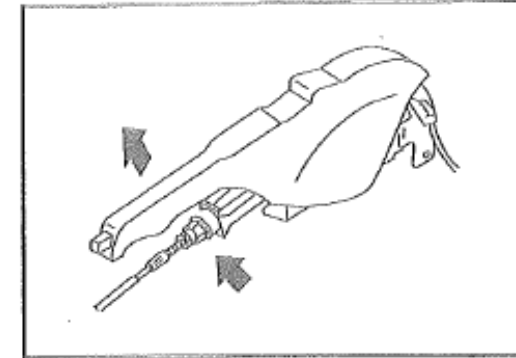
# POWERSTAR



2. Jack up the rear wheels until they are clear of the ground and place the transmission in neutral. Bring the adjusting hole in the brake drum into alignment with the adjuster by turning the propeller shaft as necessary by hand. The adjuster is located under the centerline of the transmission shaft.



3. Insert a screwdriver into the adjusting hole and turn the adjuster upward to stop.



4. Adjust the adjuster back to 30 teeth, and check the stroke of the parking brake lever.

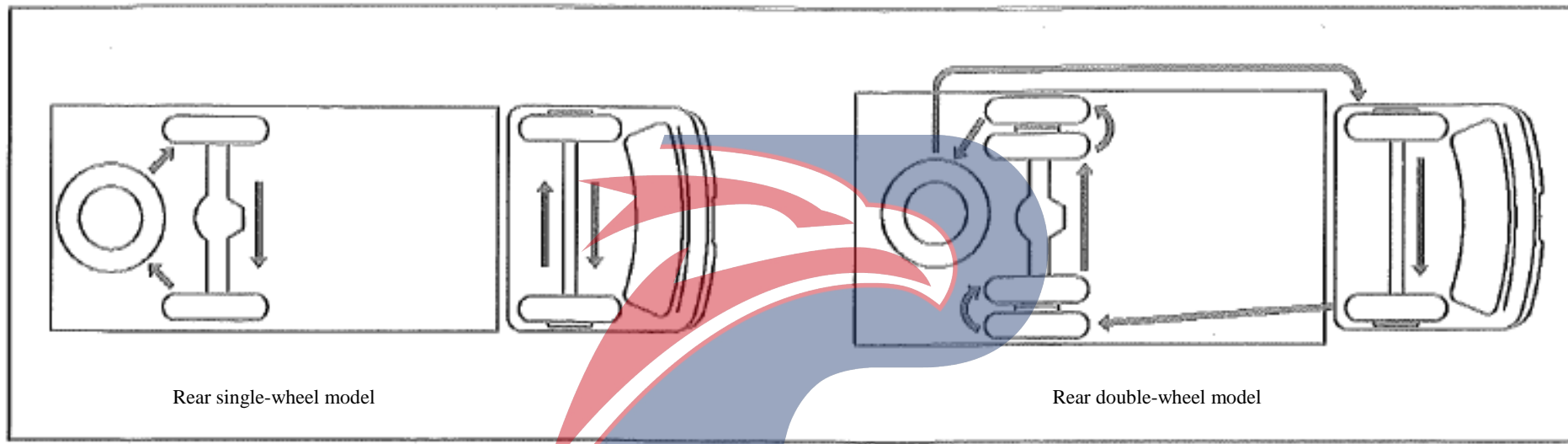
If the stroke of the parking brake lever deviates from the normal range, then it is required to adjust the length of the parking brake cable as follows.

(1) Loosen the locknut.

(2) Adjust the length of the parking brake with the adjusting nut.

(3) Tighten and lock the adjusting nut with the lock nut.

# POWERSTAR



### Replacement of tires:

In order to maintain the wear of each tire evenly and extend the service life of tire, the position of the front and rear wheels should be replaced in the order shown in the Fig.

1. Replace once every 5,000-8,000km;
2. When changing and replacing the tires, the tires shall be inspected for dynamic balance;
3. When replacing the tires, use the tires of correct specification strictly according to the instructions in the Instruction Manual;
4. When the tire is selected, the tires on the same shaft shall be "Unifying Eight Items", that is, the specification is the same, the structure is the same, the material is the same, the level is the same, the air pressure is the same, the load is the same, the pattern is the same, and the brand is the same.





### Tire inflation pressure

Tire size	Ex-factory inflation pressure (kPa)			Maximum inflation pressure (kPa)
	Front tire	Rear tire	Spare tire	
6.50-15/6.50R15	350 ±20	350 ±20	350 ±20	420/460
7.00-15/7.00R15	420 ±20	420 ±20	420 ±20	530/560
7.50-15/7.50R15	460 ±20	460 ±20	460 ±20	630/560
6.50-16/6.50R16	420 ±20	420 ±20	420 ±20	530/560
7.00-16/7.00R16	490 ±20	490 ±20	490 ±20	630/670

#### Tire inflation pressure:

The standard tire inflation pressure list is as follows:

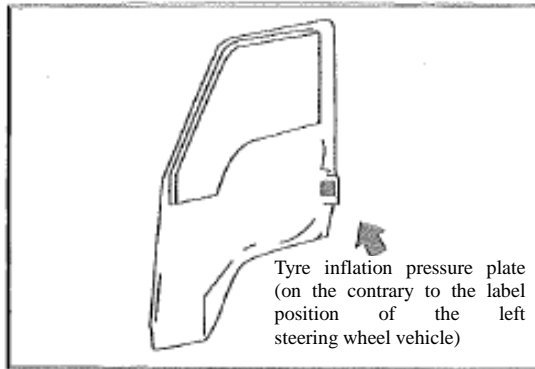
#### **NOTE**

Check or maintain tire pressure when the tires are cold. (After the vehicle has been inoperative for more than 3 hours or driven less than 1.6 km).

#### **NOTE**

The ex-factory inflation pressure is under no-load state, and the user can increase or decrease the air pressure according to actual installation quality and driving speed. Insufficient air pressure or too high pressure can cause abnormal wear of tire, affect comfort and waste fuel. However, the maximum inflation pressure must not be exceeded.

# POWERSTAR

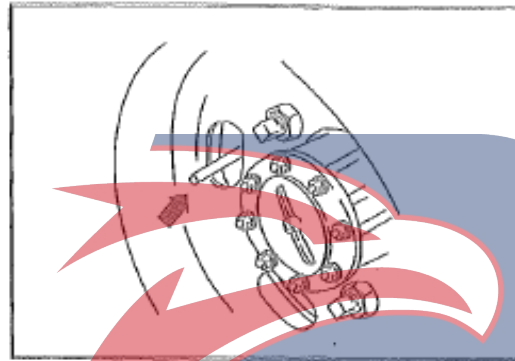


#### Tire Inflation Pressure Plate

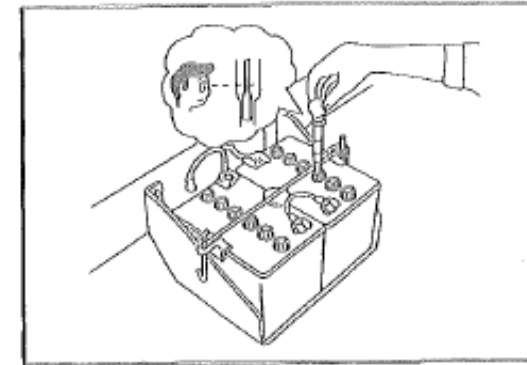
The standard value of tire inflation pressure is recorded on the tire inflation pressure plate located on the inside of the driver's side respectively.

#### WARNING

- Do not drive the vehicle unless the tire is inflated to the specified value and is in a safe state.
- If the tire inflation pressure is too large or insufficient, the operation of the vehicle will be affected, resulting in early wear and damage to the tires and even loss of control of the vehicle.



If the tire pressure is measured on the rear inner side of the double tire type vehicle, use the valve cap wrench of the general tool.

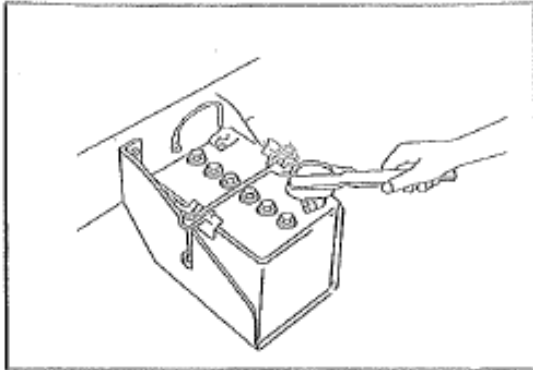


#### Specific gravity of battery electrolyte

The battery is in fully-charged state when hydrometer reading of the specific gravity is 1.26 at 20°C.

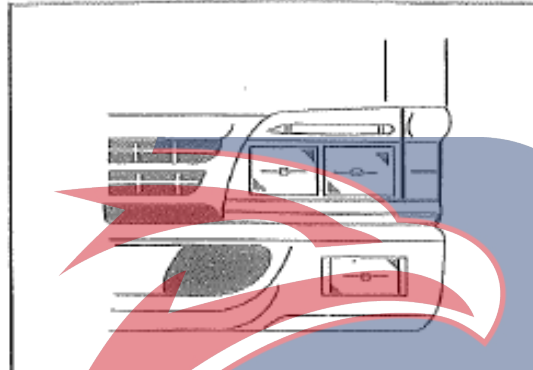
If the specific gravity is lower than 1.23, the battery is in need of recharging.

# POWERSTAR



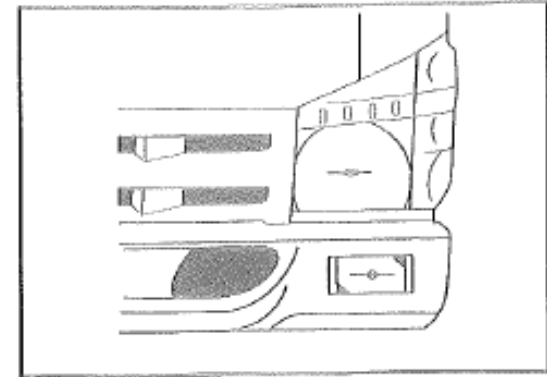
### **Cleaning of battery**

If the external part of the battery is fouled, clean with tepid water. Apply a thin coat of Vaseline or grease to the battery terminals to prevent corrosion.



### **Headlights**

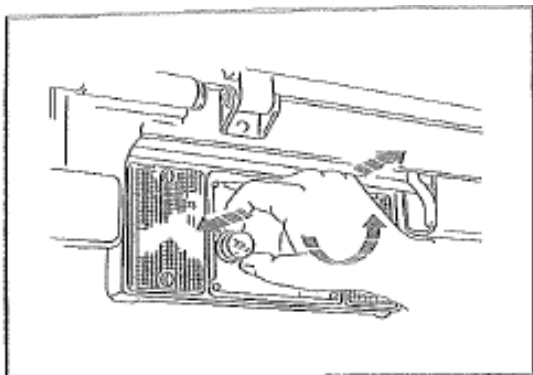
Proper aiming of the headlights is most important in assuring sufficient illumination on the highway without blinding other motorists. When lamp aiming is necessary it is advisable to contact an authorized dealer who has special equipment for this purpose.



### **Headlights**

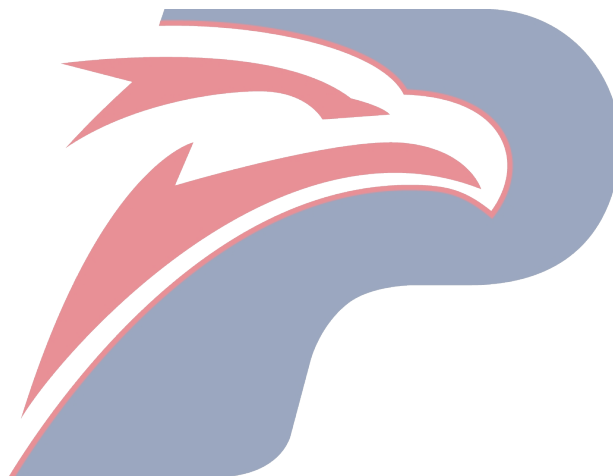
Proper aiming of the headlights is most important in assuring sufficient illumination on the highway without blinding other motorists. When lamp aiming is necessary it is advisable to contact an authorized dealer who has special equipment for this purpose.

# POWERSTAR



### Replacing lamp bulbs

The removal position of each lamp is shown in Illustration for reference. When replacing a bulb, make sure the lamp switch is "OFF". Use bulbs with the same wattage only. The standard bulb wattage ratings are given below:



# POWERSTAR



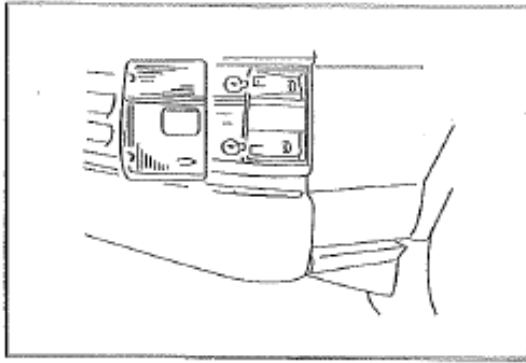
Part	Rated Power	No. of bulb	
Headlight	Outside (Type II)	45w/ 40w	2
	Inside (Type I)	45w	2
Yellow headlight	Outside	45w/ 40w	2
	Inside	45w	2
Front combination lamp	Front turn signal lamp	21w	2
	Clearance lamp	8w	2
	Side turn signal lamp	27w	2
	Stop lamp/Taillamp	21w/5w	2
Rear side combination lamp	Turn signal lamp	21w	2
	Backup lamp	21w	2
	License plate lamp	10 w	1
Dome lamp	10w	1	
Fog lamp(Front)	55w	2	
Rear fog lamps	21w	1	

**POWERSTAR**



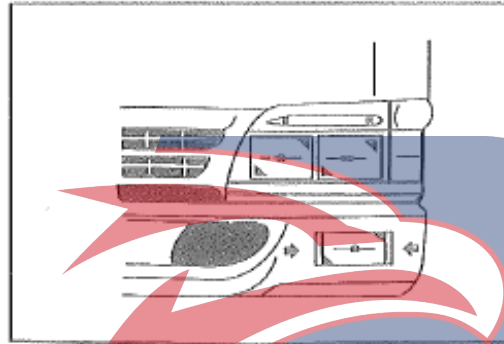
Part	Rated Power	No. of bulb	
Head lamp	50w/55w	1	
Front combination lamp	Turn signal lamp	21w	1
	Clearance lamp	5w	1
	Cornering lamp	21w	1
Rear side combination lamp	Stop lamp/Taillamp	21w/5w	2
	Turn signal lamp	21w	2
	Backup lamp	21w	2
License plate lamp	10w	1	
Dome lamp	10w	1	
Fog lamp (Front)	55w	2	
Rear fog lamps	21w	1	

# POWERSTAR



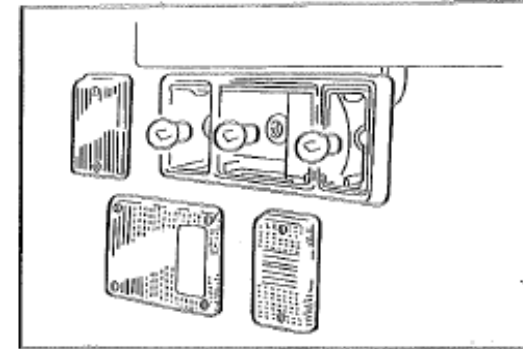
**Front combination lamp**

Unscrew the retaining screws and remove them.



**Fog lamp**

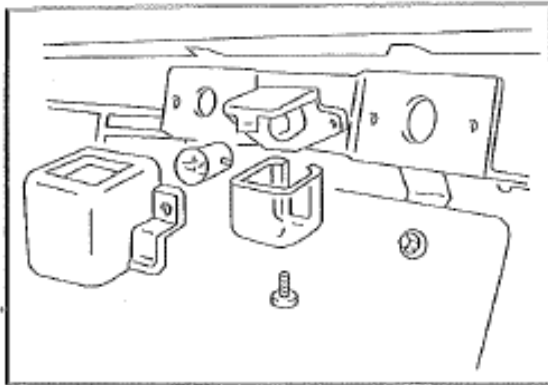
Unscrew the retaining screws and remove the fog lamp.



**Rear combination lamp**

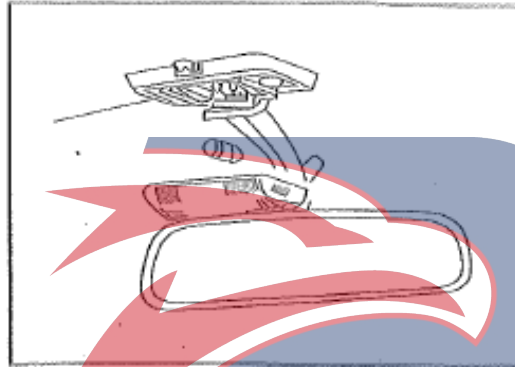
Unscrew the retaining screws and remove them.

**POWERSTAR**



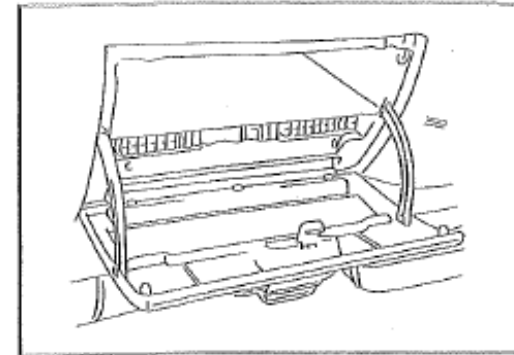
#### **License plate lamp**

Unscrew the retaining screws and remove the glass.



#### **Dome lamp**

The screwdriver can be easily pulled out as long as the screwdriver is used.



#### **Fuse box**

The fuse box is located under the toolbox. Open the hand tool cover to check and replace the fuse.

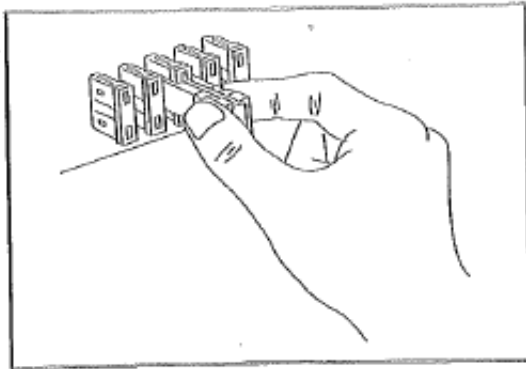
The cover can be easily pulled out manually.

The rated current value of the fuse and the applicable circuit name are recorded on the label on the inside of the box cover.

To replace the fuse, use the equipped fuse extractor.

# POWERSTAR

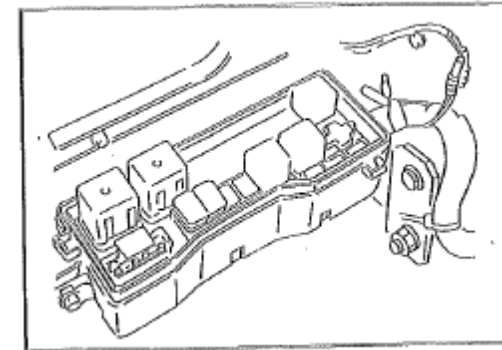
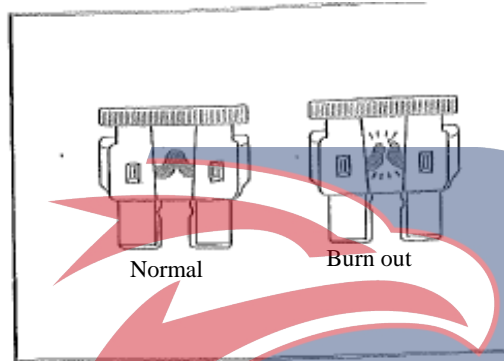




**NOTE**

If the fuse is found to fuse, check it to find out the cause of the fusing and take the necessary maintenance measures before replacing the fuse.

If replacing the fuse, you should turn the start switch to the "LOCK" position and must use a fuse with the same current value.



**Fusible connecting line**

If the headlight or other electrical components are inoperative and the fuse is normal, check the fusible connecting line. If the fusible connecting line has fused, replace the fusible connecting line with the same current value.

**WARNING**

In case of replacement, the genuine fusible connecting line of QingLing Motors must be used.

The copper wire shall not be installed even as temporary measures. It may result in greater damage and even fire.

**POWERSTAR**



If there is an overload in the circuits from the battery, the slow blow fuse and designed to melt before the entire wiring harness is damaged.

**WARNING**

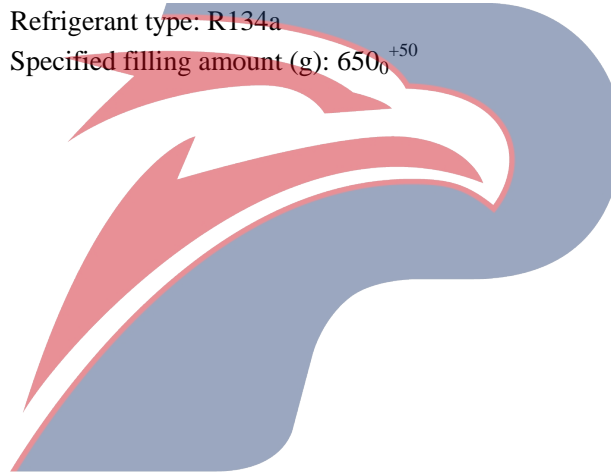
**Before replacing the fusible connecting line, make sure to find out the cause of the overload of electric power.**

**Air conditioner refrigerant**

In the process of air conditioning use, the prescribed refrigerant should be filled or replaced when it is necessary to supplement or replace the refrigerant.

Refrigerant type: R134a

Specified filling amount (g): 650<sup>+50</sup>



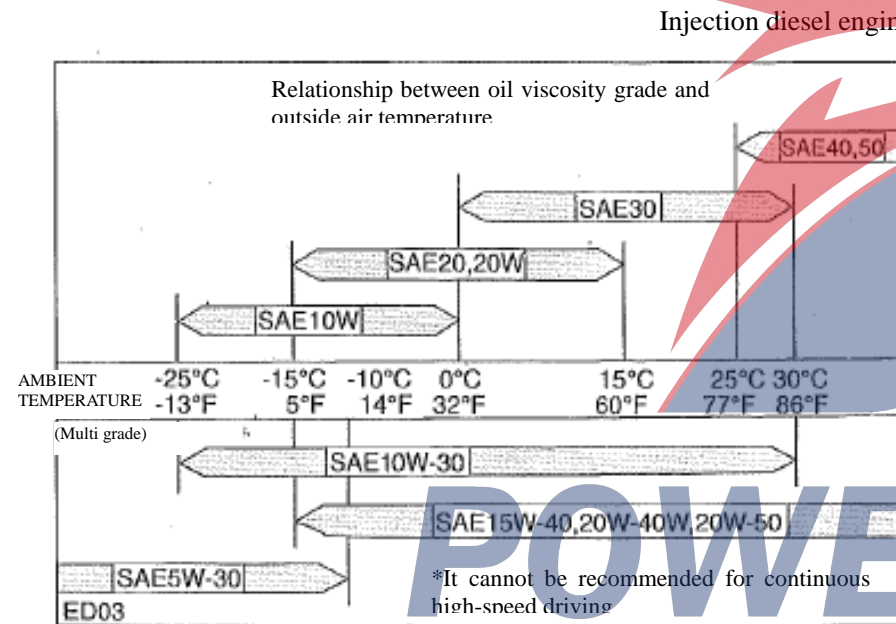
**POWERSTAR**



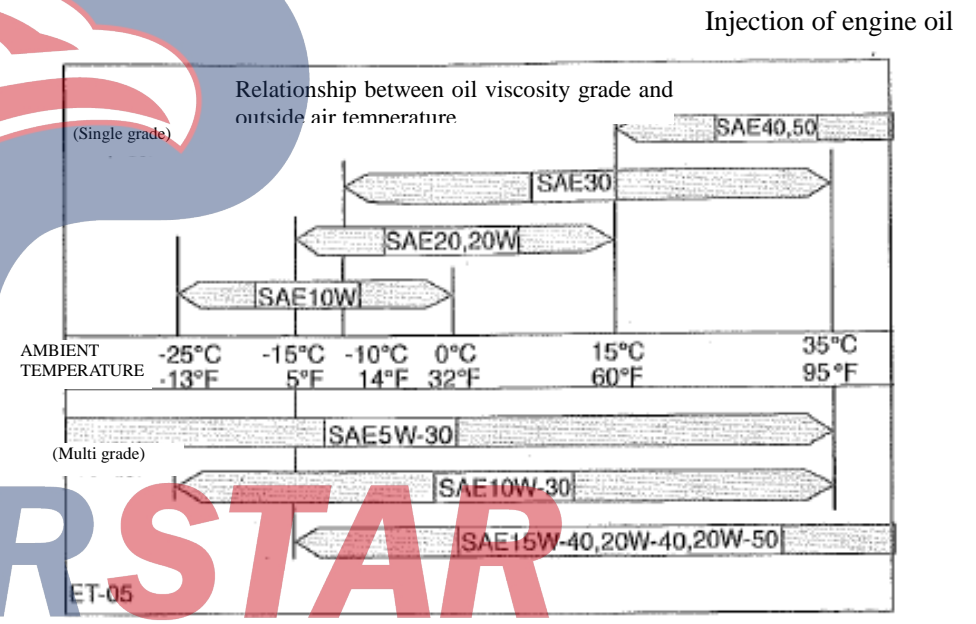
## LUBRICATION

Lubricants should be carefully selected according to the lubrication chart. It is also important to select viscosity of lubricants according to the ambient temperature by referring to the following table.

### DIESEL ENGINE OIL VISCOSITY CHART

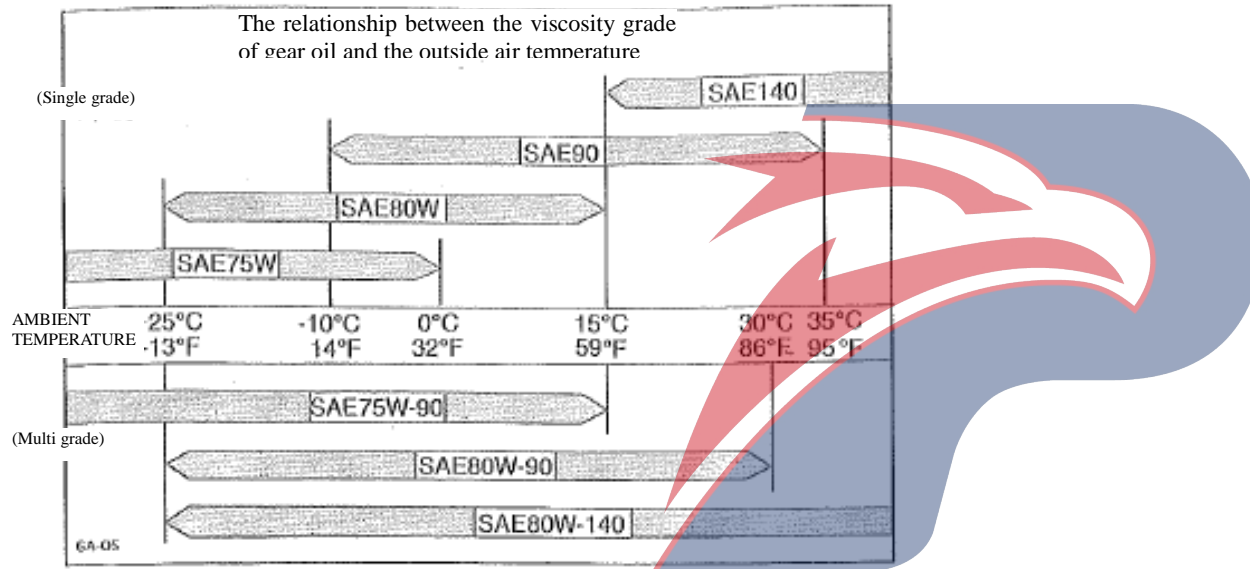


### TRANSMISSION OIL VISCOSITY CHART





### Injection gear oil



# POWERSTAR



## RECOMMENDED BRAND FOR LUBRICATING GREASE AND DIESEL OIL

In order to obtain maximum performance and longest service life from your QingLing vehicles, it is very important to select and use correctly best lubricants and diesel fuels. When lubricating, be sure to use QingLing genuine lubricants or recommended lubricants listed below, according to the maintenance schedule for each vehicle model. The lubrication intervals in the maintenance schedule and the coverage and period of new vehicle warranty are based on the use of QingLing genuine lubricants or recommended lubricants as given in the chart which will serve as a guide for selecting lubricants of proper brand name.

Part	Recommended grease
Diesel engine crankcase	Diesel oil of Class CF-4 and above
Manual transmission	Engine oil of Grade SG, SF, SE, SD or Grade SC, CE, CD or Grade CC
Rear axle Gear box	Gear oil APIGL-5
Hydraulic Brake System and Clutch System	SAEJ1703. FMVSS116 DOT.4
<input type="checkbox"/> Power steering	Automatic Transmission Oil Hyron ®-IIE

# POWERSTAR



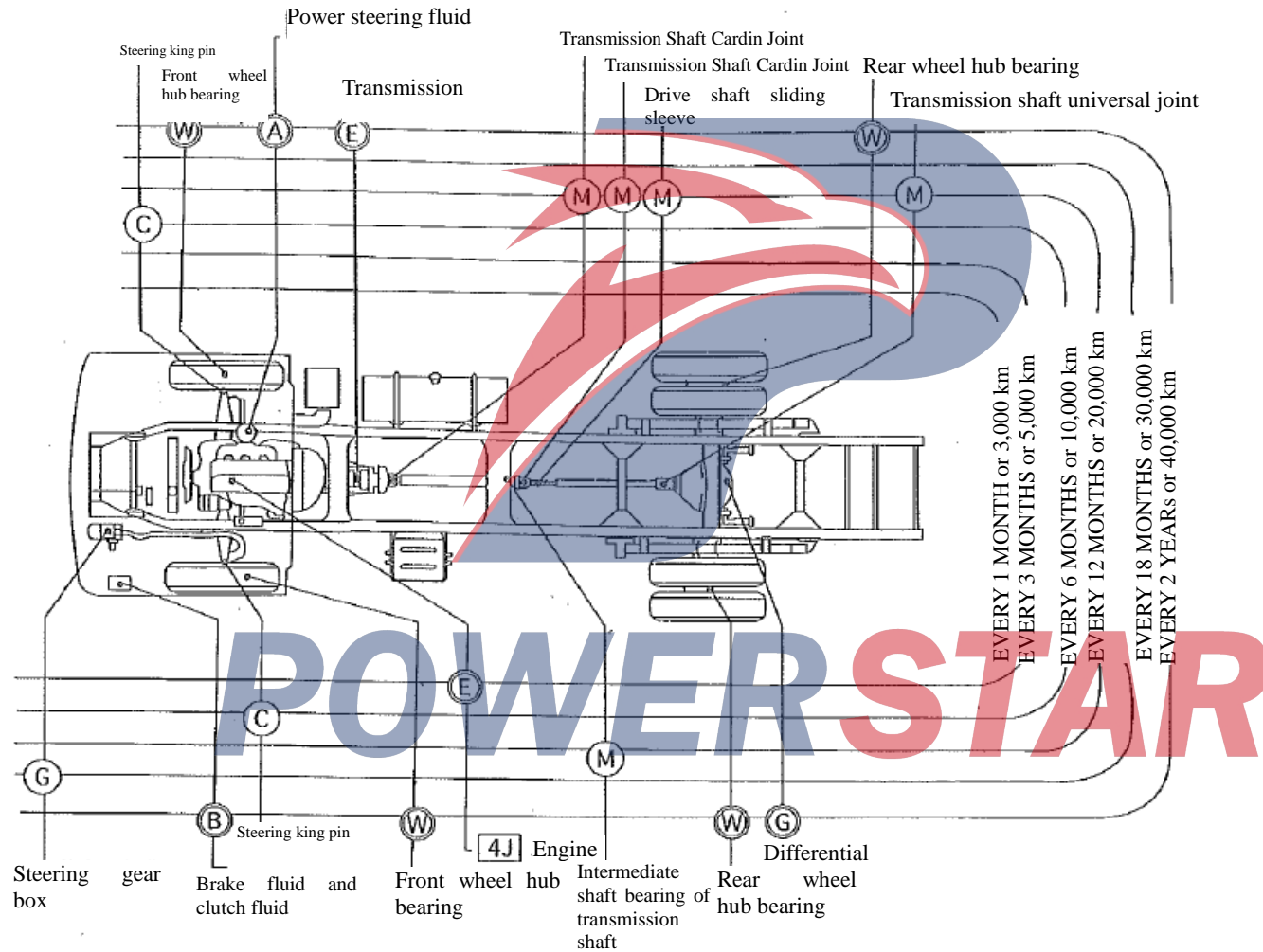
Part	Recommended grease
Engine cooling system	Antifreeze (ethylene glycol)
Wheel bearings	Wheel bearing grease or multipurpose grease NLGI No. 2 No. 3
greases	Multipurpose grease NLGI No. 1 or No. 2
Universal joint	Grease with molybdenum disulfide
Light oil	Standard
Fuel	JIS: NO. 2 SAE: NO. 2-D

API: American Petroleum Institute    SAE: American Society of Automotive Engineers    JIS: Japanese Industrial Specifications  
FMVSS: Federal Motor Vehicle Safety Standards    NLGI: National Association of Lubricating Grease Institute

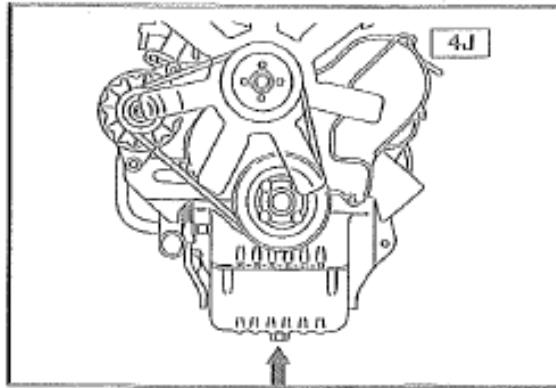
# POWERSTAR



## LUBRICATION CHART



- ⊙ Replace
- Check, supply or lubricate
- E: Engine oil
- G: Gear oil
- W: Wheel bearing grease
- C: Multipurpose grease
- M: Grease with molybdenum disulfide
- B: Brake fluid
- A: Automatic transmission fluid



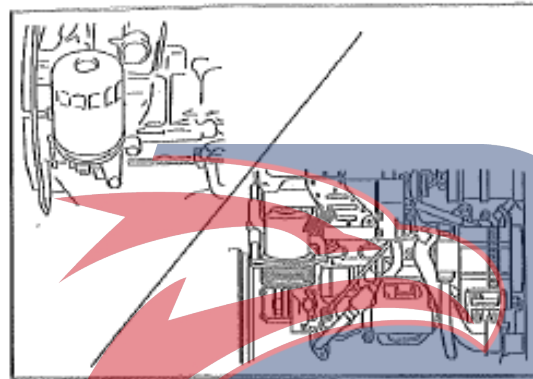
## LUBRICATION GUIDE

### Changing engine oil\*

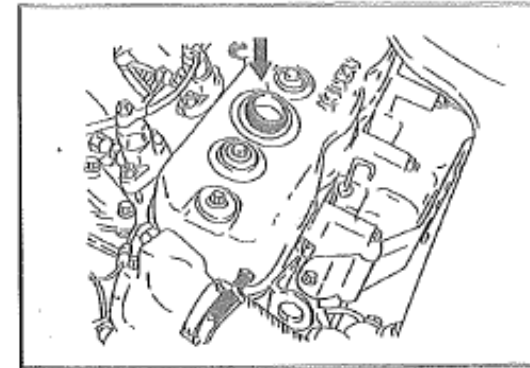
Remove the oil-drain plug at the lower part of the oil pan, main engine oil filter and the bypass oil filter to completely drain the engine oil inside the crankcase of the engine.

#### **WARNING**

**Hot engine oil can cause severe skin burns. Allow the engine to cool before draining the engine oil.**



When draining the engine oil, main oil filter and partial-flow oil filter should be completely also drained, and reassemble the drain plugs.



Fill the engine crankcase with new engine oil according to the stipulations of grade for oil filling to the engine crankcase.

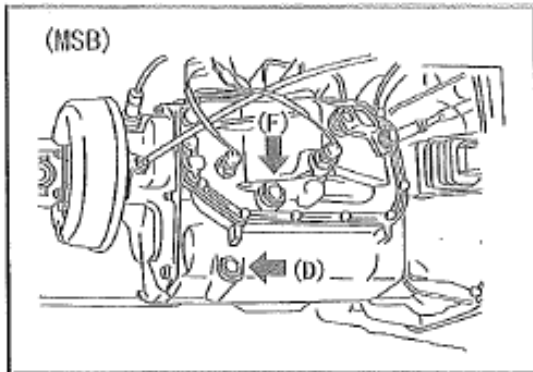
#### **NOTE**

**Please use the engine oil with the grade of CF-4 and above (refer to the section "Recommended grade for lubricating grease and diesel oil").**

When the engine crankcase is filled up to the high level mark on the oil dipstick, start and let the engine run at idle for a few minutes. Then stop the engine and recheck the oil level and replenish, as necessary.

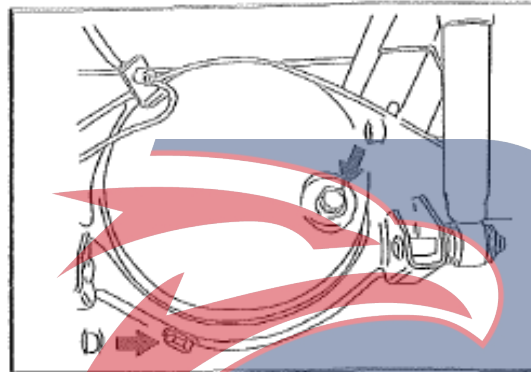
# POWERSTAR





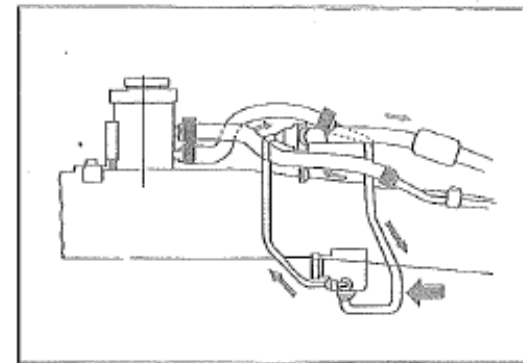
#### Changing transmission oil

Drain the rear axle case by removing the drain plug (D) on the under surface of the rear axle case. Reassemble the drain plug and fill the rear axle case up to the level plug (L) with specified gear oil through the level plug hole.



#### Changing differential oil

Drain the axle case by removing the drain plug (D) on the under surface of the front axle case. Reassemble the drain plug and fill the axle case up to the level plug (L) with specified gear oil through the level plug hole.

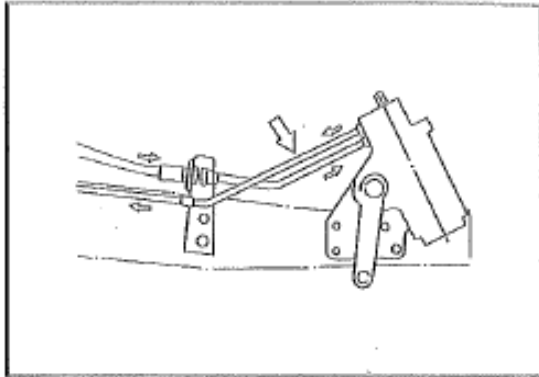


#### **OPT** Changing power steering fluid

##### Draining:

1. Jack up the front wheels until they are clear of the ground.
2. Remove the pipe between the steering mechanism and the power steering tank and the hose between the hydraulic pump and the power steering tank.
3. After the steering fluid is drained, rotate the steering wheel to the left and right and stop several times to the left and right respectively to completely discharge the residual steering fluid in the hydraulic circuit.

# POWERSTAR

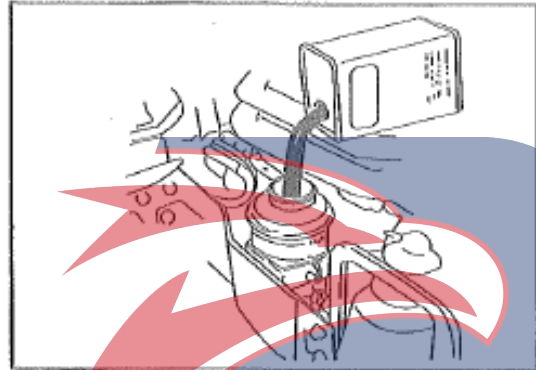


**Refilling:**

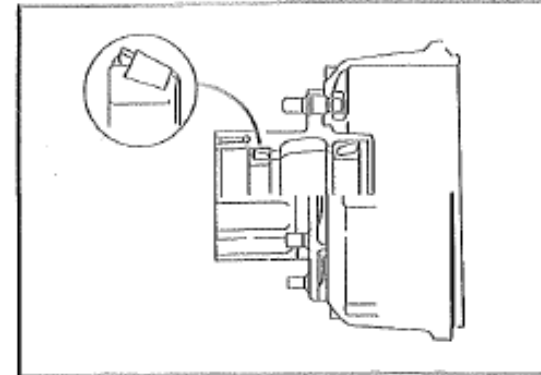
1. Tighten the joint bolts securely and fill the fluid reservoir with specified automatic transmission fluid. When the fluid reservoir is filled up to the specified level, allow 2 or 3 minutes for the fluid to get down.

**NOTE**

While refilling, keep the fluid reservoir replenished as necessary to prevent air from entering the hydraulic system.



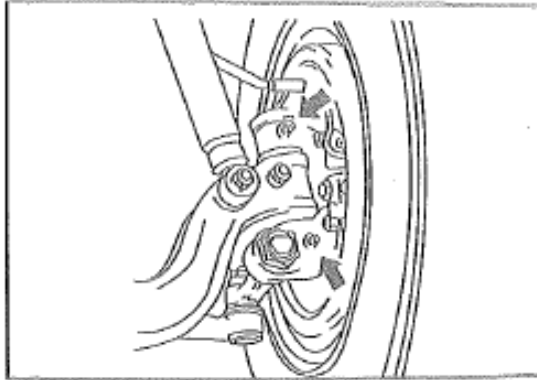
2. Lower the front wheels to the ground. Start and let the engine run at idle for a few minutes. Recheck the fluid level and replenish as necessary.



**Replace the grease for the front and rear wheel hub bearings**

If grease in the hub bearing is required to be replaced, it is necessary to remove and re-assemble the bearing, so please contact QingLing Motors Special Dealer (Maintenance Station).

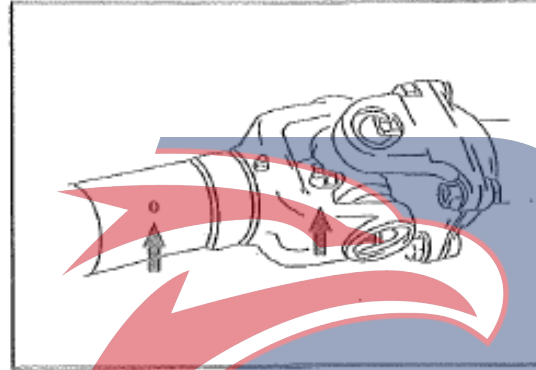
**POWERSTAR**



**Lubricating part**

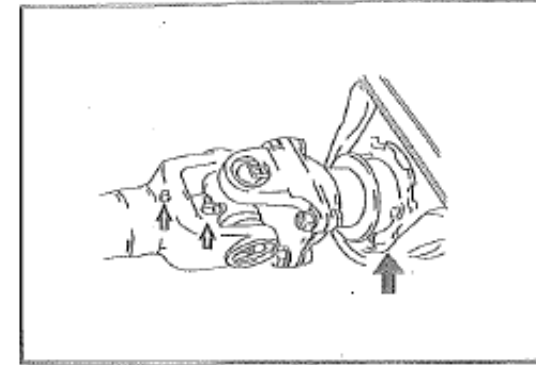
Lubricate the following parts with multipurpose grease:

Steering master pin (4 places)



Lubricate the following parts with grease containing molybdenum disulfide:

Universal joint and sliding sleeve



Lubricate the following parts with wheel bearing grease:

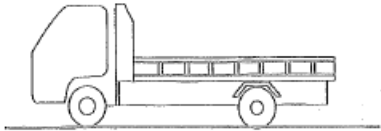
Intermediate bearing

# POWERSTAR



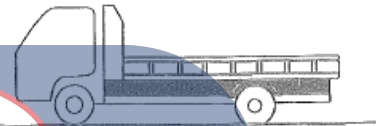
## Loading methods

### 1. Isuzu trucks, classification by usage



#### 1 Ordinary truck

(Suitable for general groceries, foods, etc.)



#### 2 Heavyweight truck

(Suitable for transporting bulk materials such as steel, cereals, etc.)

# POWERSTAR

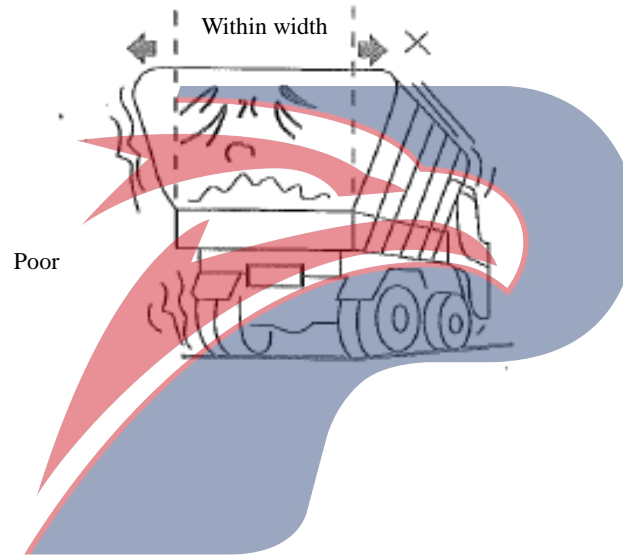


## 2. Loading limits

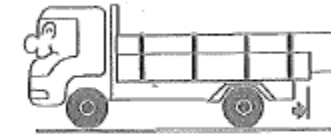


Good

1 Width of the goods cannot stick out of the truck bed.



Poor



0.5m or less  
(Not more than 1/20 of  
the total length)

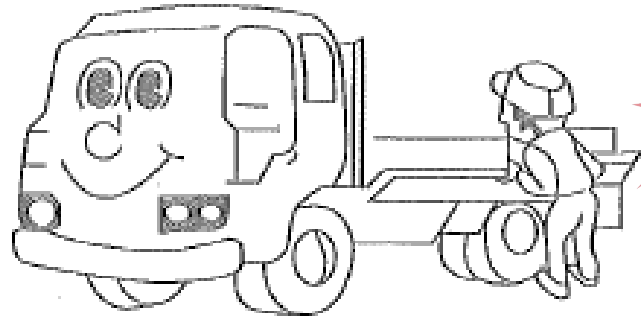
2 Do not let the goods stick out of the truck bed as much as possible.

# POWERSTAR



### 3. Loading example

Good



1 Gently open and close the sides of the truck.

Good



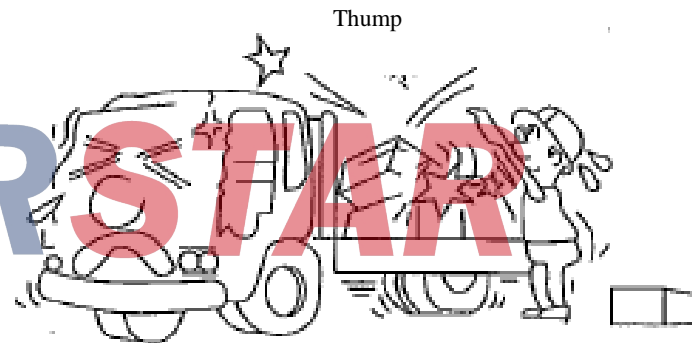
2 Unload with care.

Poor



Rough handling will shorten the life of the truck.

Poor

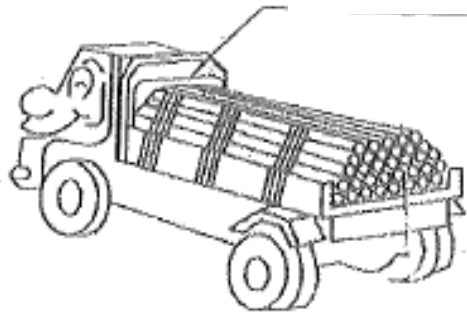


If you carelessly throw the goods around, the goods and the truck will cry out in pain.

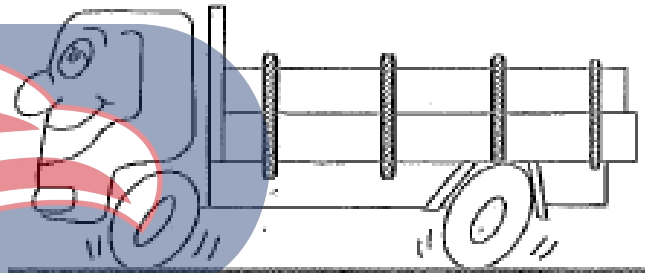


Good

Use protective plate when transporting steel



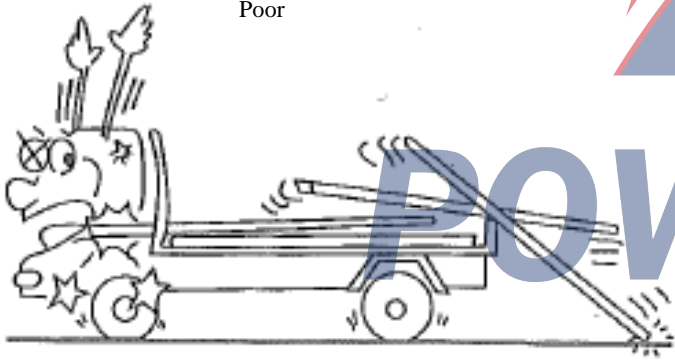
Good



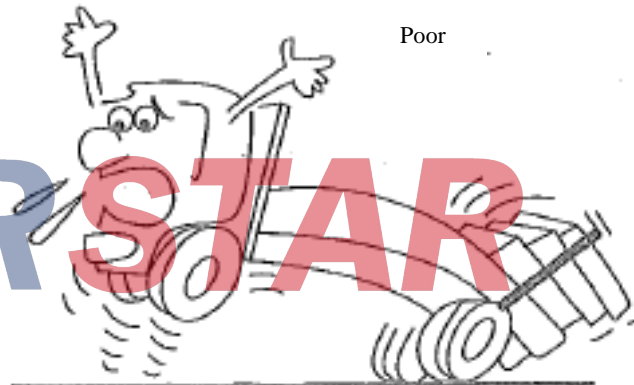
3 The goods should be bound tightly with a rope etc.

4 The goods should be loaded low and evenly.

Poor



Poor

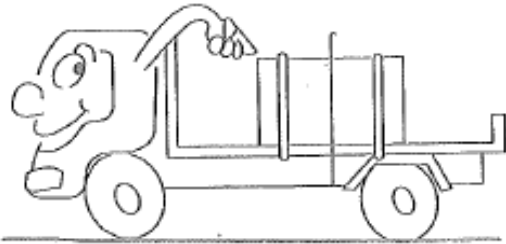


If they are not secured properly, the goods may scatter while in transit.

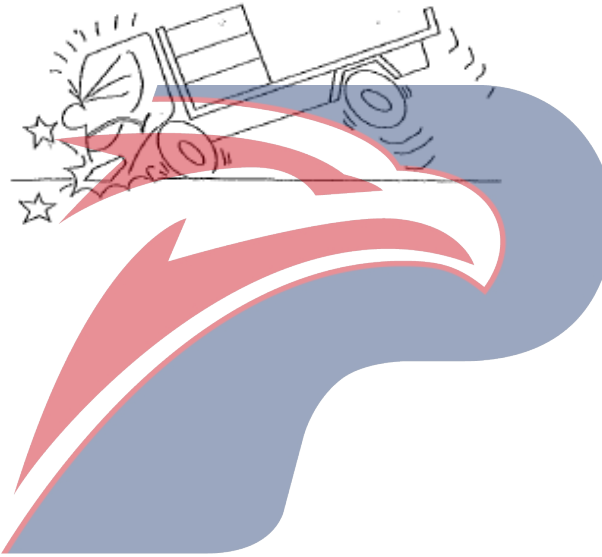
Not only will loading the goods unevenly make the vehicle unstable when driving, it may also damage the goods and the truck bed.



Good



Poor



Poor



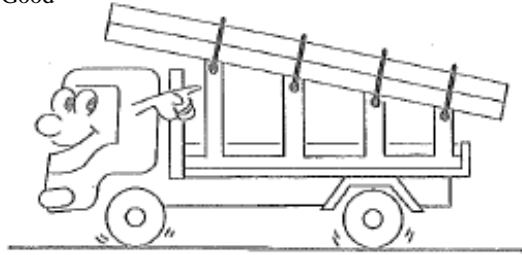
5 Large, tall items should be secured in the center of the truck bed.

# POWERSTAR





Good

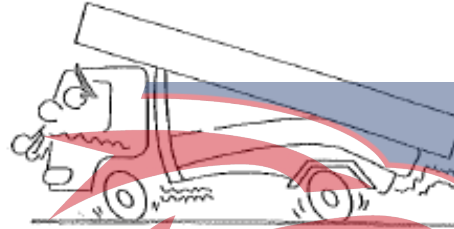


6 A rack must be used for long goods

**NOTE**

- Regulations on height limits should be given priority.
- Because this method of loading raises the center of gravity, it entails the risk of tipping the truck, so take extra caution not to drive the truck too fast or make sudden brakes or turns.

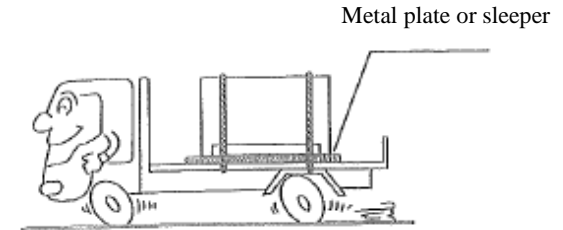
Poor



**If you only use the front frame and the rear support, the truck will groan.**

**※The rack should be counted as part of the goods.**

Good

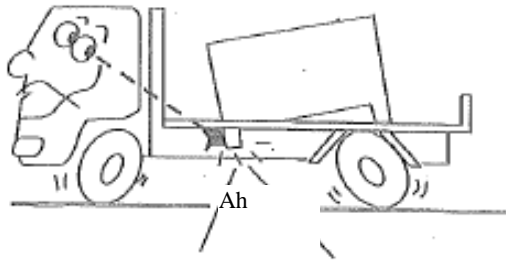


7 The weight of the goods should not be concentrated in one place but should be spread out.

# POWERSTAR



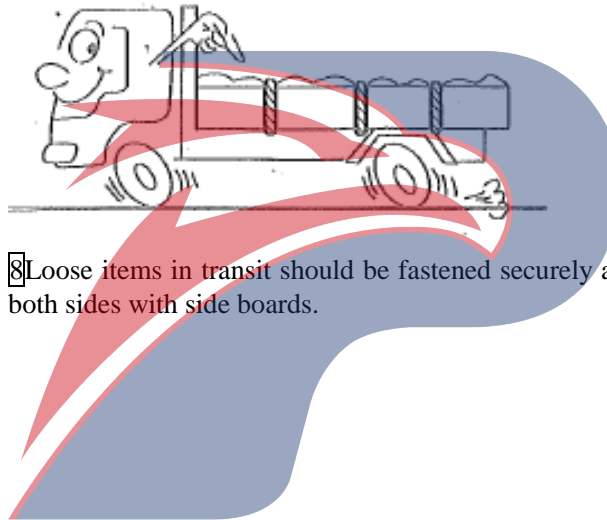
Poor



**If the load is not spread out, it will damage the bottom of the truck bed.**

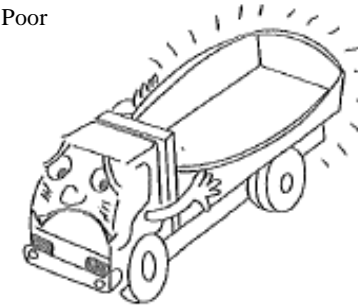
**※ A metal sheet or pallet should be counted as part of the goods.**

Good



**8** Loose items in transit should be fastened securely at both sides with side boards.

Poor

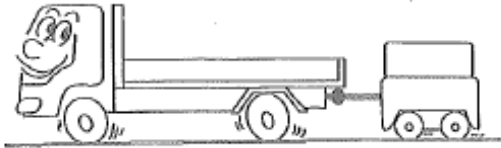


**If they are not secured, the sides of the truck bed could be deformed.**

# POWERSTAR

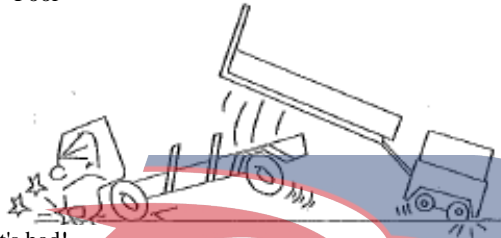


Good



9 Use the hook on the truck frame when towing.

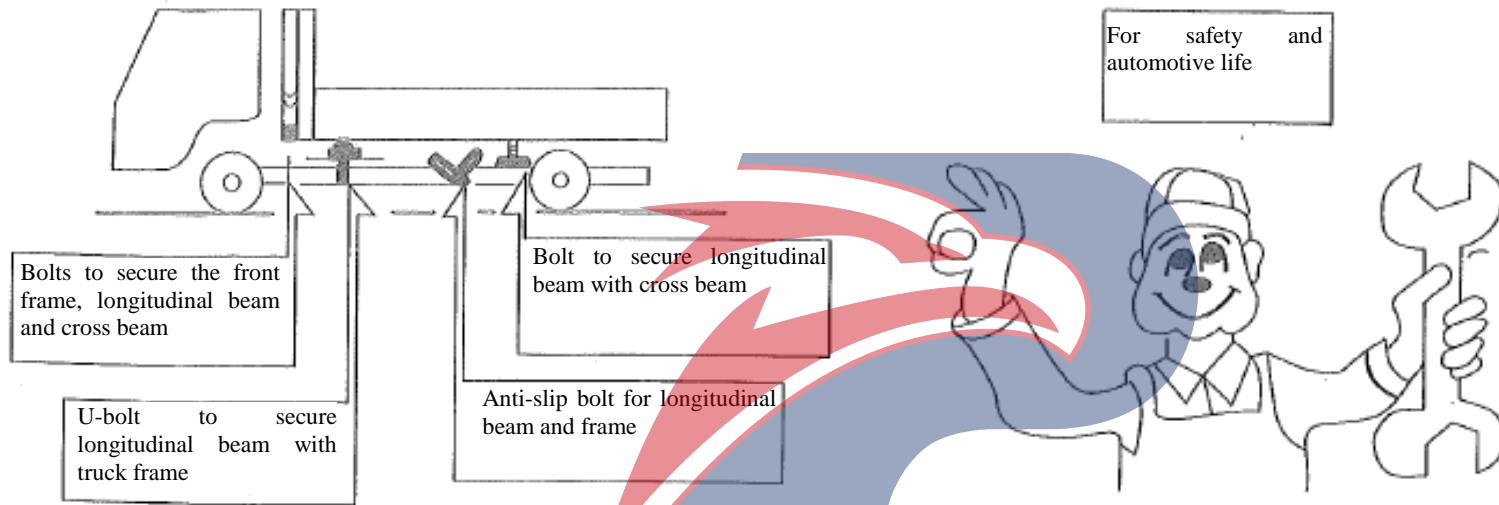
Poor



It's bad!

The truck bed should definitely not be used for towing.

# POWERSTAR

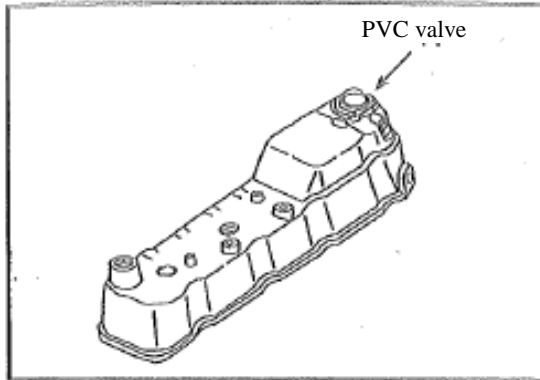


1st time	When truck is received
2nd times	One month after
3rd time	6 months after
4th time and thereafter	Every 6 months

# POWERSTAR



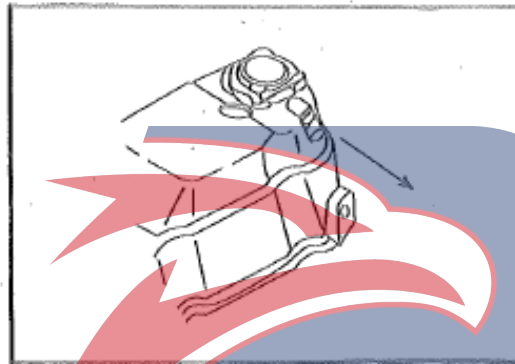
Type of goods	Loading method	Method for protecting box
Loose items such as groceries, sandy soil, gravel and bricks.		Protection for side panels and rope should be used when loading sandy soil, gravel, bricks etc
Goods that are piled high such as groceries.		Fasten with rope hooks.
<p>For large items such as machinery and equipment parts.</p> <p>Note: The center of the truck bed refers to the intersection of the diagonal lines of the bottom of the box. The line passing through this intersection point that is vertical to the truck bed is called the truck bed center line.</p>		Place steel plates, plywoods or vertical pallets on the bottom of the truck bed.
Long items such as timber, electric poles, steel pipes.		Protective material laid against the front side panel (wood or steel plate). Support with props or lay on pallets.
Over length goods (goods length exceeding the length of the container, e.g. steel plate, strip steel, etc.)		Use shelves



**Forced ventilation system for crankcase (PVC) system**

**Inspection and repair**

If excessive wear or damage is found during inspection, it is necessary to adjust, repair and replace the parts.

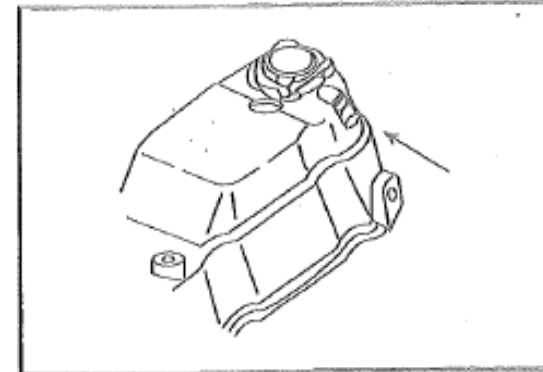


**PCV valve**

1. Blow air from cylinder head side through PCV valve

PCV valve must be opened freely.

If not, the PCV valve must be replaced.



2. Purge the air from the inlet manifold through the PCV valve.

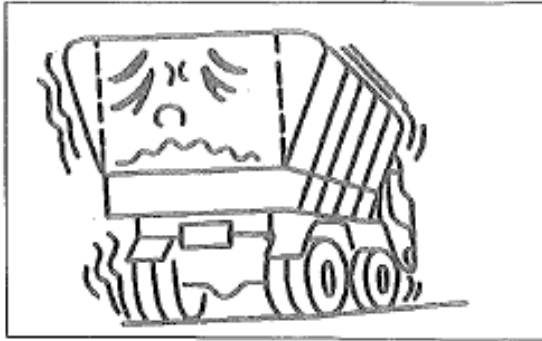
PCV valve must prevent air flow.

If not, the PCV valve must be replaced.

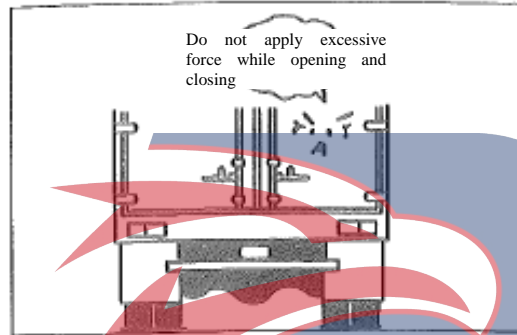
**PCV hose and connector**

Inspect the hoses and connectors for cracks, leaks, or other damage

**POWERSTAR**



1. In order to avoid premature failure of the car body, it shall be loaded according to the essentials of the load. The carrying capacity must be within the rated range of the vehicle's total mass, and it is strictly prohibited to overload the vehicle.

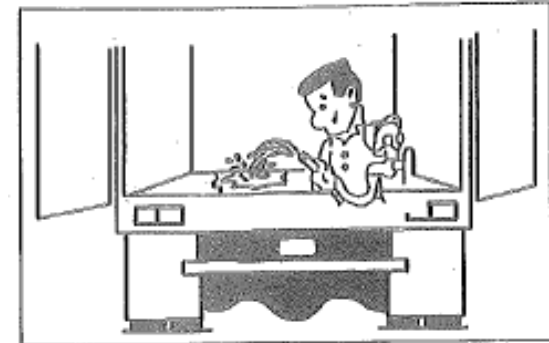


2. The opening sequence of the rear door is: the right rear door is opened first, and the left rear door is opened, the closing sequence is reverse.

**Caution:**

1) When opening and closing the rear door, it is not allowed to force the rear door to avoid bumping the car body or causing deformation of the rear door.

2) The container is of closed structure. When the rear door is closed, passengers shall not be carried in the container, and the fresh and alive animals are not suitable for shipment too.



3. After transporting corrosive substances such as strong acids and strong bases, it is required to clean the compartment in time to avoid corrosion of the compartment.

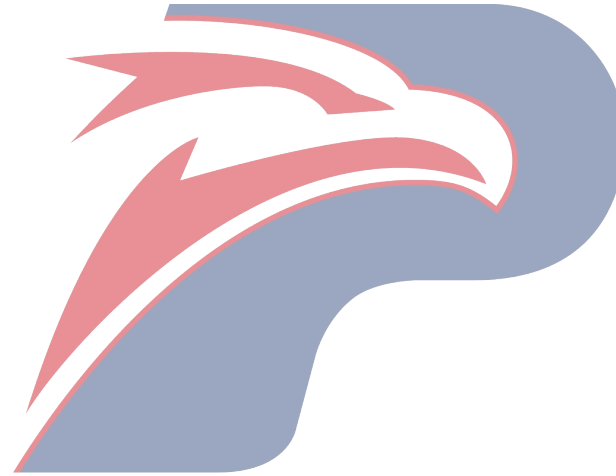
4. Take care when loading and unloading the goods to avoid injury, deformation and even damage to the vehicle body.

POWER STAR



6

## MAIN DATA AND SPECIFICATIONS



**POWERSTAR**





## MAIN DATA AND SPECIFICATIONS

Engine		
Model		4JB1CN
Type		In-line four-cylinder, water-cooled, supercharged cold, electrically controlled high-pressure common rail diesel engine
Compression ratio	(Ratio 1)	17.5+0.1
Piston displacement	(cc)	2771
Valve clearance:		
Intake valve	(mm)	0.4
Exhaust valve	(mm)	0.4
Opening pressure of injector	(bar)	270
Injection timing (static)	(°)	BTDC 0°
Firing order		1-3-4-2
Fan belt tension/force	(mm)	8-12
Idling speed	(rpm)	750+25
Engine oil capacity	(liters)	8
Coolant capacity	(liters)	10
Tightening torque of oil pan drain plug	(N • m)	45

**POWERSTAR**



## MAIN DATA AND SPECIFICATIONS

TRANSMISSION	MSB						
Model and type	For the vehicle of 5-gear with overspeed, the forward gear is synchronous engaged.						
	1st	2nd	3rd	4th	5th	Rev.	
Gear ratio	MSB-5S: 5.016	2.672	1.585	1.000	0.770	4.783	
	MSB-5MT: 5.594	2.814	1.660	1.000	0.794	5.334	
Lubricating oil capacity (L)	2.7						

# POWERSTAR



### MAIN DATA AND SPECIFICATIONS

Model and type	QL104 03EAR	QL104 03EWR	QL1040 3EWR1	QL104 03FAR	QL104 03FWR	QL105 03FI-JR	QL104 03HAR	QL105 03HAR	QL104 03HWR	QL105 03HWR	QL107 03HAR	QL106 03HWR	QL107 03KAR	QL1070 3KAR1	QL106 03KWR
<b>DIMENSIONS</b>															
Vehicle length(mm)	4800	4775		5280			5950					6745			
Vehicle width (mm)	1695							1880					1980	1880	
Vehicle Height(mm)	2160							2240					2280		
Wheel base (mm)	2490		2765			3360					3815				
Tread: Front: (mm)			1385								1504				
Rear: (mm)	1395							1425					1525	1425	
Minimum clearance (mm) lifting from the ground									≥190						
Area of compartment(m <sup>2</sup> )	4.9	3.3	6.4		4.5		7.6		5.7		7.6	5.7	9.0	10	7.1
Drive type									4X2						
Number of axles									2						
<b>Weight</b>															
Kerb mass (kg)	1980	2010		2260	2340		2370		2400	2470	2550	2580	2600	2700	2660
Loading mass(kg)	1990	1750	1250	1990	1430	1980	1950	2750	1750	2450	4500	3500	4400	4300	3500
Gross vehicle mass(kg)	4100	4085	3585	4380	4095	4645	4450	5250	4475	5245	7180	6405	7130	7130	6485
Full load shaft load: front axle (kg)	1850	1680	1535	1600	1480	1500	1785	1900	1570	1950	2480	1855	2430	2430	1870
Rear axle(kg)	2250	2405	2050	2780	2615	3145	2665	3350	2905	3295	4700	4550	4700	4700	4615
Comprehensive fuel consumption of the Ministry of Communications (L/100km)	10.7	10.6	10.2	10.7	10.6	11	10.9	13.8	10.8	13.7	15.5	15.1	15.4	15.4	15.2
Fuel consumption implementation standard	JT719 Fuel Consumption Limits and Measurement Methods for Operating Truck														
Max. speed of vehicle									98km/h				95km/h		
Maximum gradeability									≥30%				≥28%		
Emission level	GB17691—2005(GB IV) ,GB3847-2005														
Number of passengers allowed in the cab (person)	2	2+3	2	2+3	2		2+3		2			2+3	2	2+3	



## MAIN DATA AND SPECIFICATIONS

Vehicle model	QL104 03EAR	QL104 03EWR	QL1040 3EUR1	QL104 03FAR	QL104 03FWR	QL105 03FWR	QL104 03HAR	QL105 03HAR	QL104 03HWR	QL105 03HWR	QL107 03HAR	QL106 03HWR	QL107 03KAR	QL1070 3KAR1	QL106 03KWR
<b>ENGINE</b>															
Model	4JB1CN														
Rated power (kW/ rpm)	72/3400														
Maximum net power (kW/ rpm)	71/3400														
Torque (N • m/ rpm)	220/1700														
combustion type	Diesel														
Fuel tank volume (L)	75	63	100	84	100	84	100	84	100	84	100	84	100	84	100
<b>CLUTCH</b>															
Type	Hydraulic control, diaphragm spring, single-chip dry type														
Diameter (mm)	φ250														
Pedal free play (mm)	12 ~22														
<b>TRANSMISSION</b>															
Model	MSB-5S					MSB-5MT									
<b>REAR AXLE</b>															
Type	Full Floating, Spiral Small Umbrella Gear and hypoid Gear Drive														
hypoid gear diameter (mm)	φ244					φ292									
Gear ratio (ratio 1)	5.571					6.142									
Lubricating oil capacity (L)	2.7					3									



## MAIN DATA AND SPECIFICATIONS

Vehicle model	QL104 03EAR	QL104 03EWR	OL1040 3EWR1	QL104 03FAR	QL104 03FWR	QL105 03FWR	QL104 03HAR	QL105 03HAR	01104 03HWR	0L1Q5 03HWR	QL107 03HAR	QL106 03HWR	0L107 03KAR	0L1070 3KAR1	QL106 03KWR
<b>STEERING</b>															
Steering Position	Left														
Type	Recirculating balls														
Steering wheel free play (mm)	10-30														
Capacity (L)	0.54														
<b>Front wheel alignment</b>															
Toe-in (mm)	3-7 (oblique tire); 0 ~ 4 (radial tire)														
Camber (°)	1°15'±30'														
Caster (°)	1. 30'± 60'														
King pin angle (°)	7°15'±40'														
<b>SERVICE BRAKE</b>															
Type	Dual-circuit hydraulic brake system with vacuum booster														
Pedal free play (mm)	4-7														
<b>PARKING BRAKE</b>															
Type	Center drum brake acting on the output shaft of the transmission														
Brake lever travel (notches)	5 ~ 8 (when pulling upward with 150 N)														



## MAIN DATA AND SPECIFICATIONS

Vehicle model	QL104 03EAR	QL104 03EWR	QL1040 3EWR1	QL104 03FAR	QL104 03FHR	QL105 03FWR	QL104 03HAR	QL105 03HAR	QL104 03HWR	QL105 03HWR	QL107 03HAR	QL106 03HWR	0L107 03KAR	QL1070 3KAR1	QL106 03KWR
<b>SUSPENSIONS</b>															
Type: Front/Rear	Semi-elliptical alloy steel leaf springs with hydraulic double acting telescopic shock absorbers														
Specification: front/ rear	6+5					8/6+5									
<b>WHEELS</b>															
Tire Size: Front wheel	7.00-15 10PR 52 or 7.00R15 10PR	7.00- 1510PR or 7.00R1 510PR	7.00-15 10PR or 7.00R15 10PR	6.50-15 10PR or 6.50R15 10PR			7.00-15 10PR or 7.00R15 10PR				7.00-16 14PR or 7.00R16 14PR				
Rear wheel	7.50-15 10PR or 7.50R15 10PR		7.50-15 10PR or 7.50R15 10PR												
<b>ELECTRICAL</b>															
Type	12 Volt Electrical System for Negative pole Grounding														
Battery (Volt/Amp.h.)	12/ 80 (2 in parallel)														
Starter (Volt/kw)	12 / 2.6														
AC generator (Volt/Amp.h.)	12 / 60														



## MAIN DATA AND SPECIFICATIONS

Vehicle model	QL5040X XY3EAR	QL5040X XY3EWR	QL5040X XY3FAR	Q15040X1 XY3FVIR	QL5050X XY3HWR	QL5040X XY3HWR	QL5040X XY3HAR	QL5050X XY3HAR	QL5070X XY3HAR	QL5070X XY3HWR	QL5070X XY3KVIR	QL5070X XY3KAR	QL5070X XY3KAR1
<b>DIMENSIONS</b>													
Vehicle length (mm)	4870	4940	5385	5370				5995					6790
Vehicle width (mm)	1768/1818	1768		1860/1910						1880/1910		1880/1905	2110/2160
Vehicle Height (mm)	2695/2740	2495	2790/2835	2700		2790/2710	2790/2835	2825	2750	2825		2900	2900
Wheel base (mm)	24	90	27	65			3360					3815	
Tread: Front: (mm)				1385							1504		
Rear: (mm)		1395					1425						1525
Minimum clearance (mm) lifting from the ground							≥190						
Area of compartment (m <sup>2</sup> )	5.3	3.8	6.4	4.7	5.7			7.5		5.7	7.2	9.0	10.3
Drive type							4x2						
Number of axles							2						
<b>Weight</b>													
Kerb mass (kg)	2340	2370/2430	2530	2700	2750/2840	2760	2705	2790/2920/2800	2900/2800	2900	3020	3050/2900	3150/3000
Loading mass (kg)	1450	1250/1190	1450	1350	1850/1760	1350	1600	1990/1860/1980	4000/4100	3300	3300	3850/4000	3850/4000
Gross vehicle mass(kg)	3920	3945	4110	4375	4925	4435	4435	4910	7030	6525	6645	7030	7130
Full load shaft load: Front axle (kg)	1670	1600	1510	1350	1700	1550	1780	1785	2380	1820	1950	2370	2430
Rear axle(kg)	2250	2345	2600	3025	3225	2885	2655	312S	4650	4705	4695	4660	4700
Comprehensive fuel consumption of the Ministry of Communications (L/ 100km)	10.4	10.5	10.7	10.8	11.1	10.9	10.9	11.1	16.5	IS.7	IS.8	16.4	16.6
Fuel consumption implementation standard	JT 719 Fuel, Consumption Limits and Measurement Methods for Operating Truck												
Max. speed of vehicle	98km/h					95km/h							
Maximum gradeability	≥30%					≥28%							
Emission Level	GB17691-2005(GB IV)GB3847-2005												
Number of passengers allowed in the cab (person)	2	2+3	2	2+3	2	2+3	2	2+3	2	2+3	2	2+3	2+3



### MAIN DATA AND SPECIFICATIONS

Vehicle model	QL5040X XY3EAR	QL5040X XY3FWR	QL5040X XY3FAR	QL5040X XY3FWR	QL5050X XY3HWR	QL5040X XY3HWR	QL5040X XY3HAR	QL5050X XY3HAR	QL5070X XY3HAR	QL5070X XY3HWR	QL5070X XY3KWR	QL5070X XY3KAR	QL5070X XY3KAR1
<b>ENGINE</b>													
Model	4JB1CN												
Rated power (kW/ rpm)	72/3400												
Maximum net power (kW/ rpm)	71/3400												
Torque (N • m/ rpm)	220/1700												
Fuel type	Diesel												
Fuel tank capacity (liters)	76	63	100	100	100	84	100	100	84	100	84	100	100
<b>CLUTCH</b>													
Type	Hydraulic control, diaphragm spring, single-chip dry type												
Diameter (mm)	φ250												
Pedal free play(mm)	12 ~22												
<b>TRANSMISSION</b>													
Model and type	MSB-5S						M5B-5MT						
<b>REAR AXLE</b>													
Type	Full Floating, Spiral Small Umbrella Gear and hypoid Gear Drive												
Hypoid gear diameter (180m)	φ244						φ292						
Gear ratio (ratio1)	5.571						6.142						
Lubricating oil capacity (liters)	2.7						3						





### MAIN DATA AND SPECIFICATIONS

Vehicle model	QL5040X XY3EAR	QL5040X XY3EHR	QL5040X XY3FAR	QL5040X XY3FWR	QL5050X XY3HWR	QL5040X XY3HHR	QL5040X XY3HAR	QL5050X XY3HAR	QL5070X XV3HAR	QL5070X XY3HWR	QL5070X XY3KHR	QL5070X XV3KAR	QL5070X XY3KAR1
<b>STEERING</b>													
Steering position	Left												
Type	Circulating-ball type												
Steering wheel free play (mm)	10-30												
Capacity (L)	0.54												
Front wheel alignment													
Toe-in (mm)	3-7 (oblique tire); 0 ~ 4 (radial tire)												
Camber (°)	1°15'±30'												
Caster (°)	1°30'±60'												
King pin angle (°)	7°15'±40'												
<b>SERVICE BRAKE</b>													
Type	Dual-circuit hydraulic brake system with vacuum booster												
Pedal free play (mm)	4-7												
<b>PARKING BRAKE</b>													
Type	Center drum brake acting on the output shaft of the transmission												
Brake lever travel (notches)	5 ~ 8 (when pulling upward with 150 N.)												



### MAIN DATA AND SPECIFICATIONS

Vehicle model	QL5040X XY3EAR	QL5040X XY3EWR	QLS040X XY3FAR	QL6040X XY3FWR	QL5050X XY3HWR	QL5040X XY3HHR	QL5040X XY3HAR	QL5050X XY3HAR	QL5070X XY3HAR	QL5070X XY3HHR	QL5070X XY3KHR	QL5070X XV3KAR	QL5070X XY3KAR1
<b>SUSPENSIONS</b>													
Type; Front/Rear	Semi-elliptical alloy steel leaf springs with hydraulic double acting telescopic shock absorbers												
Specification: front/ rear	6+5			8/6+5									
<b>WHEELS</b>													
Tire Size: front wheel	7.00-15 10PR or 7.00R15 10PR		6.50-15 10PR or 6.50R15 10PR		7.00-15 10PR or 7.00R1B 10PR			7.00-16 14PR or 7.00R16 14PR					
Rear wheel	7.50-15 10PR or 7.50R15 10PR												
<b>ELECTRICAL</b>													
Type	12 Volt Electrical System for Negative pole Grounding												
Battery (Volt-Amp.h.)	12/ 80 (2 in parallel)												
Starter (volt/kw)	12 / 2.6												
AC generator(volt/amp.)	12 / 60												

# POWERSTAR



## MAIN DATA AND SPECIFICATIONS

Vehicle model	QL5040X XY3EARJ	QL5040X XY3EWRJ	QL5040X XV3FARJ	QL5040X XY3FWRJ	QL5050X XY3HWRJ	QL5040X XY3HWRJ	QL5040X XY3HARJ	QL5050X XY3HARJ	QL5070X XY3HARJ	QL5070X XY3HWRJ	QL5070X XV3KWRJ	QL5070X XY3KARJ	QL5070XX Y3KAR1J	
<b>DIMENSIONS</b>														
Vehicle length (mm)	4870	4940	5385	5370				5995					6790	
Vehicle width (mm)	1768/1818	1768				1860/1910			1880/1910		1880/1905			12110/2160
Vehicle Height (mm)	2695	2495	2790/2835	2700	2790/2710		2790/2835		2825	2750	2825	2900		
Wheel base (mm)	2490		2765			3360							3815	
Tread: Front: (mm)											1504			
Rear: (mm)	1395						1425						1525	
Minimum clearance (mm) lifting from the ground								≥190						
Area of compartment (m <sup>2</sup> )	5.3	3.8	6.4	4.7	6	7	7.5		—	5.7	1.?	9.0	10.3	
Drive type								4X2						
Number of axles								2						
<b>Weight</b>														
Kerb mass (kg)	2340	2370/2430	2530	2700	2750/2840	2760	2705	2790/2920/2800	2900/2800	2900	3020	3050/2900	3150/3000	
Loading mass (kg)	1450	1250/1190	1450	1350	1850/1760	1350	1600	1990/1850/1980	4000/4100	3300	3300	3850/4000	3850/4000	
Gross vehicle mass (kg)	3920	3945	4110	4375	4925	4435	4435	4910	7030	6525	6645	7030	7130	
Full load shaft load: front axle (kg)	1670	1600	1510	1350	1700	1550	1780	1785	2380	1820	1950	2370	2430	
Rear axle (kg)	2250	2345	2600	3025	3225	2885	2655	3125	4650	4705	4695	4660	4700	
Comprehensive fuel consumption of the Ministry of Communications (L/100km)	10.4	10.5	10.7	10.8	11.1	10.9	10.9	11.1	16.1	15.3	15.8	16	16.3	
Fuel consumption implementation standard	JT719 Fuel Consumption Limits and Measurement Methods for Operating Truck													
Max. speed of vehicle							98km/h							95km/h
Maximum gradeability							≥30%							≥28%
Emission Level	GB17691-2005(GB IV),GB3847-2005													
Number of passengers allowed in the cab (person)	2	1	2+3	2	2+3	2	2+3	2	2+3	2	2+3	2		



### MAIN DATA AND SPECIFICATIONS

Vehicle model	QL5040X	QL5040X	QL5040X	QL5040X	QL5050X	QL5040X	QL5040X	QL5050X	QL5070X	QL5070X	QL5070X	QL5070XX	QL5070X
	XY3EARJ	XY3EWRJ	XY3FARJ	XY3R-JRJ	XY3HHRJ	XY3HHRJ	XY3HARJ	XY3HARJ	XY3HARJ	XY3HWRJ	XY3KWRJ	Y3KAR1J	XY3KARJ
ENGINE													
Model	4JB1CN												
Rated power (kW/ rpm)	72/3400												
Maximum net power (kW/ rpm)	71/3400												
Torque (N • m/ rpm)	220/1700												
Fuel type	Diesel												
Fuel tank capacity (liters)	75	63	100		84		100		84		100		84
CLUTCH													
Type	Hydraulic control, diaphragm spring, single-chip dry type												
Diameter (mm)	φ250												
Pedal free play (mm)	12 ~22												
TRANSMISSION													
Model and type	MSB-5S						M5B-5MT						
REAR AXLE													
Type	Full Floating, Spiral Small Umbrella Gear and hypoid Gear Drive												
Hypoid gear diameter (180m)	φ244						φ292						
Gear ratio (ratio 1)	5.571						6.142						
Lubricating oil capacity (liters)	2.7						3						



### MAIN DATA AND SPECIFICATIONS

Vehicle model	QL5040X	QL5040X	QL5040X	QL5040X	QL5050X	QL5040X	QL5040X	QL5050X	QL5070X	QL5070X	QL5070X	QL5070n	QL5070X
	XV3EARJ	XY3EHRJ	XY3FARJ	XY3FWRJ	XY3HWRJ	XY3HWRJ	XY3HARJ	XY3HARJ	XY3HARJ	XY3HWRJ	XY3KWRJ	V3KAR1J	XY3KARJ
<b>STEERING</b>													
Steering Position	Left												
Type	Circulating-ball type												
Steering wheel free play (mm)	10-30												
capacity (L)	0.54												
Front wheel alignment													
Toe-in (mm)	3-7 (oblique tire); 0 ~ 4 (radial tire)												
Camber (°)	1°15'±30'												
Caster (°)	1°30'±60'												
King pin angle (°)	7°15'±40'												
<b>SERVICE BRAKE</b>													
Type	Dual-circuit hydraulic brake system with vacuum booster												
Pedal free play (mm)	4-7												
<b>PARKING BRAKE</b>													
Type	Center drum brake acting on the output shaft of the transmission												
Brake lever travel (notches)	5 ~ 8 (when pulling upward with 150 N.)												



### MAIN DATA AND SPECIFICATIONS

Vehicle model	QL5040X XY3EARJ	QL5040X KY3EWRJ	QL5040X XY3FARJ	QL5040X XY3FWRJ	QL5050X XY3HHRJ	QL5040X XY3HWRJ	QL5040X KY3HARJ	QL5050X XY3HARJ	QL5070X XY3HARJ	QL5070K XY3HWRJ	QL5070K XY3KWRJ	QL5070H Y3KARIJ	QL5070H XY3KARJ
<b>SUSPENSIONS</b>													
Type; Front/Rear	Semi-elliptical alloy steel leaf springs with hydraulic double acting telescopic shock absorbers												
Specification: front/ rear	6+5			8/6+5									
<b>WHEELS</b>													
Tire Size: front wheel	7.00-15 10PR or 7.00R15 10PR		6.50-15 10PR or 6.50R15 10PR		7.00-15 10PR or 7.00R15 10PR				7.00-16 14PR or 7.00R16 14PR				
Rear wheel	7.50-15 10PR or 7.50R15 10PR												
<b>ELECTRICAL</b>													
Type	12 Volt Electrical System for Negative pole Grounding												
Battery (Volt/Amp.h.)	12/ 80 (2 in parallel)												
Starter (volt/kw)	12/2.6												
AC generator(Volt/Amp.h.)	12/60												

# POWERSTAR



## MAIN DATA AND SPECIFICATIONS

Vehicle model	QL5041X XY3KARJ	QL5043X XY3HARJ	QL5040X LC3HARJ							
<b>DIMENSIONS</b>										
Vehicle length (mm)	5995	5995	5995							
Vehicle width (mm)	2160	2160	1 975							
Vehicle Height (mm)	3080	3080	2930							
Wheel base (mm)	3360	3360	3360							
Tread: Front: (mm)	1504	1504	1385							
Rear: (mm)	1525	1525	H25							
Minimum clearance (mm) lifting from the ground		≥190								
Area of compartment (m <sup>2</sup> )	8.7	8.7	7.1							
Drive type			4X2							
Number of axles				2						
<b>Weight</b>										
Kerb mass (kg)	2705	2290	3145							
Loading mass (kg)	1495	1245	1 200							
Gross vehicle mass (kg)	4330	3665	4475							
Full load shaft load: front axle (kg)	1740	1385	1800							
Rear axle (kg)	2590	2280	2675							
Comprehensive fuel consumption of the Ministry of Communications (L/100km)	≤10.8	≤10.4	<11							
Fuel consumption implementation standard	JT719 Fuel, Consumption Limits and Measurement Methods for Operating Truck									
Max. speed of vehicle	98km/h									
Maximum gradeability	≥30%									
Emission Level	GB 17691-2005(GB IV), GB3847-2005									
Number of passengers allowed in the cab (person)	2	2	2							



### MAIN DATA AND SPECIFICATIONS

Vehicle model	QL5041X	QL5043X	QL5040X										
	XY3HARJ	XY3HARJ	LC3HARJ										
<b>ENGINE</b>													
Model	4JB1CN												
Rated power (kW/ rpm)	72/3400												
Maximum net power (kW/ rpm)	71/3400												
Torque (N • m/ rpm)	220/1700												
Fuel type	Diesel												
Fuel tank capacity (liters)	100												
<b>CLUTCH</b>													
Type	Hydraulic control, diaphragm spring, single-chip dry type												
Diameter (mm)	φ250												
Pedal free play(mm)	12 ~22												
<b>TRANSMISSION</b>													
Model and type	MSB-5S			M5B-5MT									
<b>REAR AXLE</b>													
Type	Full Floating, Spiral Small Umbrella Gear and hypoid Gear Drive												
Hypoid gear diameter (180m)	φ292												
Gear ratio (ratio 1)	6.142												
Lubricating oil capacity (liters)	3												





### MAIN DATA AND SPECIFICATIONS

Vehicle model	QL5041X XY3HARJ	QL5043X XY3HARJ	QL5040X LC3HARJ										
<b>STEERING</b>													
Steering Position	Left												
Type	Circulating-ball type												
Steering wheel free play (mm)	10-30												
capacity (L)	0.54												
<b>Front wheel alignment</b>													
Toe-in (mm)	3-7 (oblique tire); 0 ~ 4 (radial tire)												
Camber (°)	1°15'±30'												
Caster (°)	1°30'±60'												
King pin angle (°)	7°15'±40'												
<b>SERVICE BRAKE</b>													
Type	Dual-circuit hydraulic brake system with vacuum booster												
Pedal free play (mm)	4-7												
<b>PARKING BRAKE</b>													
Type	Center drum brake acting on the output shaft of the transmission												
Brake lever travel (notches)	5 ~ 8 (when pulling upward with 150 N,)												



### MAIN DATA AND SPECIFICATIONS

Vehicle model	QL5041X XY3HARJ	QL5043X XY3HARJ	QL5040X LC3HARJ									
<b>SUSPENSIONS</b>												
Type: Front/Rear	Semi-elliptical alloy steel leaf springs with hydraulic double acting telescopic shock absorbers											
Specification: Front/ rear	8/6+5											
<b>WHEELS</b>												
Tire Size: Front wheel	7.00-15 10PR or 7.00R15 10PR		6.50-15 8PR or 6.50R158PR		7.00-15 10PR or 7.00R15 10PR							
Rear wheel												
<b>ELECTRICAL</b>												
Type	12 Volt Electrical System for Negative Pole Grounding											
Battery (Volt/Amp.h.)	12/ 80 (2 in parallel)											
Starter (volt/kw)	12 / 2.6											
AC generator(Volt/Amp)	12 / 60											

# POWERSTAR



**Table of Chassis Parameters of Series N**

Project	Unit	Chassis model						
		QL10433HARY	QL10443HARY					
Emission Level		GB17691-2005(IV),GB384 7-2005						
Number of passengers allowed in the cab	人	2						
Kerb mass		1855	1710					
Chassis axle load	Front axle	kg	1200	915				
	Rear axle	kg	655	795				
Allowable maximum total mass	kg	4495	3665					
maximum axle load	Front axle	kg	1805	1385				
	Rear axle	kg	2690	2280				
Vehicle length	mm (OL)	5900						
Vehicle width(at cab)	mm	1695						
Vehicle width(at rear axle)	mm (BWL)	1980			1 980			
Vehicle height	mm (OH)	2180						
Wheel base	mm (WB)	3360						
Front track	mm (FW)	1504						
Rear track	mm (BWB)	1525						
Front suspension	mm	1015						
Rear Overhang	mm ( ROH)	1525						
Approach angle	°	24°						
Departure angle	° (a)	20°						



### MAIN DATA AND SPECIFICATIONS

Model and type	QL5040XXY 3EWR2	QL5050XXY 3HAR1	QL10403EW R2	QLI0503HA R1	QL5040XXY 3EWR2J	QL5050XXY 3HARIJ	QL10403HH R	QL5040XLC 3EARJ	QL5041CCY 3EWRJ	QL5050CCY 3KARJ	QL5040XXY 3HHRJ
<b>DIMENSIONS</b>											
Vehicle length (mm)	4940	5995	4775	5950	4940	5995	5950	4870	4940	5995	5995
Vehicle width(mm)	1768	1860/1910	1695	1880	1768	1860/1910	1880	1768/1819	1818	1910	1905/1880
Vehicle Height (mm)	2495	2790/2835	2160	2240	2495	2790/2835	2240	2270	2715	2800	2790/2845
Wheel base (mm)	2490	3360	2490	3360	2490	3360	3360	2490	2490	3360	3360
Tread: Front: (mm)	1305	1385	1385	1305	1385	1385	1385	1385	1385	1385	1335
Rear: (mm)	1395	M25	1395	1425	1395	1425	1425	1395	1395	1425	1425
Minimum clearance (mm) lifting from the ground	≥190										
Area of compartment(m <sup>2</sup> )	3.8	7.5	3.3	7.6	3.8	7.5	6.8	4.9	3.8	7.6	6.8
Drive type	4X2										
Number of axles	2										
<b>Weight</b>											
Kerb mass (kg)	2370/2430	2920/2790/2800	2010	2370	2370/2430	2920/2790/2800	2370	2520	2200	2660	2705
Loading mass(kg)	1250/1190	1860/1990/1980	1750	2750	1250/1190	1860/1990/1980	1950	1450	1495	2510	1600
Gross vehicle mass(kg)	3945	4910	4085	5250	3945	4910	4450	4100	4100	5300	4435
Full load shaft load: front axle (kg)	1600	1785	1380	1900	1600	1785	1785	1850	1690	1920	1780
Rear axle(kg)	2345	3125	2405	3350	2345	3125	2665	2250	2410	3380	2655
Comprehensive fuel consumption of the Ministry of Communications (L/100km)	11	11.2	10.6	13.8	10.5	11.1	15	12	12.6	14.2	15
Fuel consumption implementation standard	JT719 Fuel Consumption Limits and Measurement Methods for Operating Truck										
Max. speed of vehicle	98km/h										
Maximum gradeability	≥30%										
Emission Level	GB17691—2005(GBIV) ,GB3847-2005										
Number of passengers allowed in the cab (person)	2+3	2	2+3	2	2+3	2	2	2	2+3	2	2



### MAIN DATA AND SPECIFICATIONS

Vehicle model	QL5040XXY 3EWR2	QL5050XXY 3HAR1	QL10403EW R2	QLI0503HA R1	QL5040XXY 3EWR2J	QL5050XXY 3HARIJ	QL10403HH R	QL5040XLC 3EARJ	QL5041CCY 3EWRJ	QL5050CCY 3KARJ	QL5040XXY 3HHRJ
ENGINE	4JB1CN										
Model	72/3400										
Rated power (kW/ rpm)	71/3400										
Maximum net power (kW/ rpm)	220/1700										
Torque (N • m/ rpm)								220/1700			
Fuel type								Diesel			
Fuel tank capacity (liters)	63	100	63	100	63	100	100	75	63	100	100
CLUTCH											
Type								Hydraulic control, diaphragm spring, single-chip dry type			
Diameter (mm)								φ250			
Pedal free play(mm)								12 ~22			
TRANSMISSION											
Model and type	MSB-5S	MSB-5MT	MSB-5S	MSB-5MT	MSB-5S	MSB-5MT	MSB-5MT	MSB-5S	MSB-5S	MSB-5MT	MSB-5MT
REAR AXLE											
Type								Full Floating, Spiral Small Umbrella Gear and hypoid Gear Drive			
Hypoid gear diameter (180m)	φ244	φ292	φ244	φ292	φ244	φ292	φ292	φ244	φ244	φ292	φ292
Gear ratio (ratio 1)	5,571	6.142	5.571	6.142	5.571	6.142	6.142	5.571	5.571	6.142	6.142
Lubricating oil capacity (liters)	2.7	3	2.7	3	2.7	3	3	2.7	2.7	3	3



## MAIN DATA AND SPECIFICATIONS

Vehicle model	QL5040X XY3EWR2	QL5050XXY 3HAR1	QL10403EW R2	QLI0503HA R1	QL5040XXY 3EWR2J	QL5050XXY 3HARIJ	QL10403HH R	QL5040XLC 3EARJ	QL5041CCY 3EWRJ	QL5050CCY 3KARJ	QL5040XXY 3HHRJ
<b>STEERING</b>											
Steering Position	Left										
Type	Circulating-ball type										
Steering wheel free play (mm)	10-30										
capacity (L)	0.54										
Front wheel alignment											
Toe-in (mm)	3-7 (oblique tire); 0 ~ 4 (radial tire)										
Camber (°)	1°15'±30'										
Caster (°)	1°30'±60'										
King pin angle (°)	7°15'±40'										
<b>SERVICE BRAKE</b>											
Type	Dual-circuit hydraulic brake system with vacuum booster										
Pedal free play (mm)	4-7										
<b>PARKING BRAKE</b>											
Type	Center drum brake acting on the output shaft of the transmission										
Brake lever travel (notches)	5 ~ 8 (when pulling upward with 150 N.)										



### MAIN DATA AND SPECIFICATIONS

Vehicle model	QL5040X	QL5050X	QL10403	QL10503	QL5040XX	QL5050XX	QL10403	QL5040X	QL5041C	QL5050C	QL5040X	QL5040X
	XY3EWR2	XY3HAR1	EWR2	HAR1	Y3EWR2J	Y3HAR1J	HHR	LC3EARJ	CY3EWRJ	CY3HARJ	XY3HHRJ	XY3EWR2
<b>SUSPENSIONS</b>												
Type: Front/Rear	Semi-elliptical alloy steel leaf springs with hydraulic double acting telescopic shock absorbers											
Specification: front/rear	6/5	8/6+5	6/5	8/6 + 5	6/5 8/6+5 6/5		8/6+5		6/5		8/6+5	
<b>WHEELS</b>												
Tire Size: front wheel	7.00-15 10PR or 7.00R15 10PR	7.00-15 10PR or 7.00R15 10PR	7.00-15 10PR or 7.00R15 10PR	7.00-15 10PR or 7.00R15 10PR	7.00-15 10PR or 7.00R15 10PR		7.00-15 10PR or 7.00R15 10PR	7.00-15 10PR or 7.00R15 10PR	7.00-15 10PR or 7.00R15 10PR	7.00-16 14PR or 7.00R16 14PR	7.00-15 10PR or 7.00R15 10PR	
Rear wheel	7.50-15 12PR or 7.50R15 10PR		7.50-15 12PR or 7.50R15 10PR		7.50-15 12PR or 7.50R15 10PR						7.50-15 12PR or 7.50R15 10PR	
<b>ELECTRICAL</b>												
Type	12 Volt Electrical System for Negative pole Grounding											
Battery (Volt-Amp.h.)	12/ 80 (2 in parallel)											
Starter (volt/kw)	12 / 2.8											
AC generator(volt/amp.)	12 / 60											

POWER STAR



## MAIN DATA AND SPECIFICATIONS

Vehicle model	QL104 I3EAR	QLI0413FAR	QL10413HAR	QL10413HWR	QL504 2XXY3HAR
<b>DIMENSIONS</b>					
Vehicle length (mm)	4800	5280	5950	5995	
Vehicle width (mm)	1695		1880		
Vehicle Height (mm)	2160	2240	2700		
Wheel base (mm)	2490	2765	3360		
Tread: Front: (mm)	1395		1425		
Rear: (mm)	1395		1425		
Minimum clearance (mm) lifting from the ground	1395		≥190		
Area of compartment(m <sup>2</sup> )	4.9	6.4	7.6	5.7	7.5
Drive type	4X2				
Number of axles	2				
<b>Weight</b>					
Kerb mass (kg)	1980	2160	2165	2400	2280
Loading mass(kg)	1400	1490	1495	1490	1240
Gross vehicle mass (kg)	3510	3780	3790	4215	3650
Full load shaft load: front axle (kg)	1580	1300	1525	1480	1380
Rear axle(kg)	1930	2400	2265	2735	2270
Comprehensive fuel consumption of the Ministry of Communications (L/100km)	11	11.2	10.6	13.8	10.5
Fuel consumption implementation standard	JT719 Fuel Consumption Limits and Measurement Methods for Operating Truck				
Max. speed of vehicle	98km/h				
Maximum gradeability	≥30%				
Emission Level	G8 17691 -2005 (GB IV) . GB3847-2005				
Number of passengers allowed in the cab (person)	2	2+3	2+3		2





## MAIN DATA AND SPECIFICATIONS

Vehicle model	QL10413EAR	QL10413FAR	QL10413HAR	QL5042XXY3HAR	QL10413HWR
ENGINE					
Model	4JB1CN				
Rated power (kW/ rpm)	72/3400				
Maximum net power (kW/ rpm)	71/3400				
Torque (N • m/ rpm)	220/1700				
Fuel type	Diesel				
Fuel tank capacity (liters)	75	100			84
CLUTCH					
Type	Hydraulic control, diaphragm spring, single-chip dry type				
Diameter (mm)	≥ 250				
Pedal free play(mm)	12 ~22				
TRANSMISSION					
Model and type	MSB-5S			MSB-5MT	
REAR AXLE					
Type	Full Floating, Spiral Small Umbrella Gear and hypoid Gear Drive				
Hypoid gear diameter (180m)	φ244			φ292	
Gear ratio (ratio 1)	5.571			6.142	
Lubricating oil capacity (liters)	2.7			3	



### MAIN DATA AND SPECIFICATIONS

Vehicle model	QL10413EAR	QL10413FAR	QL10413HAR	QL5042XXY3HAR	QL10413HWR
<b>STEERING</b>					
Steering Position	Left				
Type	Circulating-ball type				
Steering wheel free play (mm)	10-30				
capacity (L)	0.54				
<b>Front wheel alignment</b>					
Toe-in (mm)	3-7 (oblique tire); 0 ~ 4 (radial tire)				
Camber (°)	1°15'±30'				
Caster (°)	1°30'±60'				
King pin angle (°)	7°15'±40'				
<b>SERVICE BRAKE</b>					
Type	Dual-circuit hydraulic brake system with vacuum booster				
Pedal free play (mm)	4-7				
<b>PARKING BRAKE</b>					
Type	Center drum brake acting on the output shaft of the transmission				
Brake lever travel (notches)	5 ~ 8 (when pulling upward with 150 N.)				

**POWER STAR**



### MAIN DATA AND SPECIFICATIONS

Vehicle model	QL10413EAR	QL10413FAR	QL10413HAR	QL5042XXY3HAR	QL10413HWR
<b>SUSPENSIONS</b>					
Type; Front/Rear	Semi-elliptical alloy steel leaf springs with hydraulic double acting telescopic shock absorbers				
Specification: front/ rear	6/5				8/6+5
<b>WHEELS</b>					
Tire Size: Front wheel	7.00-15 10PR or 7.00R15 10PR		6.50- 15 8PR or 6.50R15 8PR		6.50- 15 10PR or 6.50R15 10PR
Rear wheel					
<b>ELECTRICAL</b>					
Type	12 Volt Electrical System for Negative pole Grounding				
Battery (Volt-Amp.h.)	12/ 80 (2 in parallel)				
Starter (volt/kw)	12 / 2.8				
AC generator(volt/amp.)	12 / 60				

# POWERSTAR



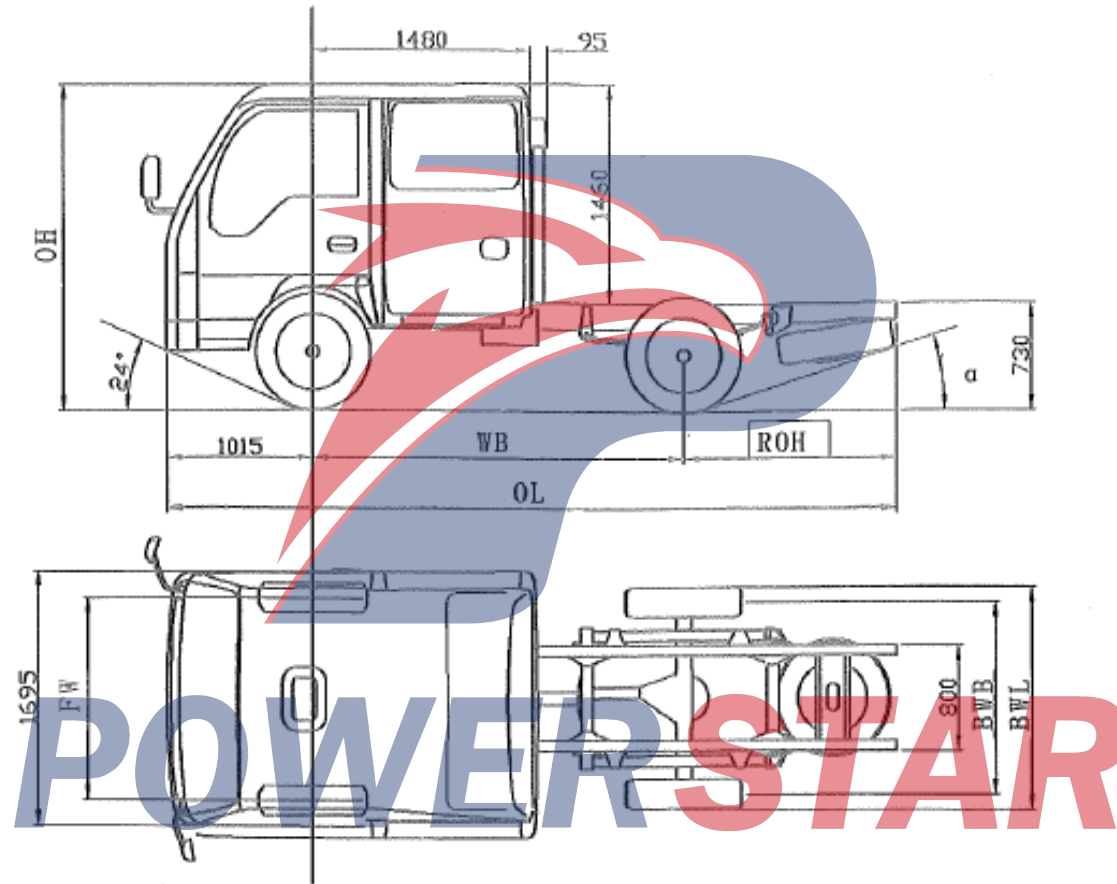
## MAIN DATA AND SPECIFICATIONS

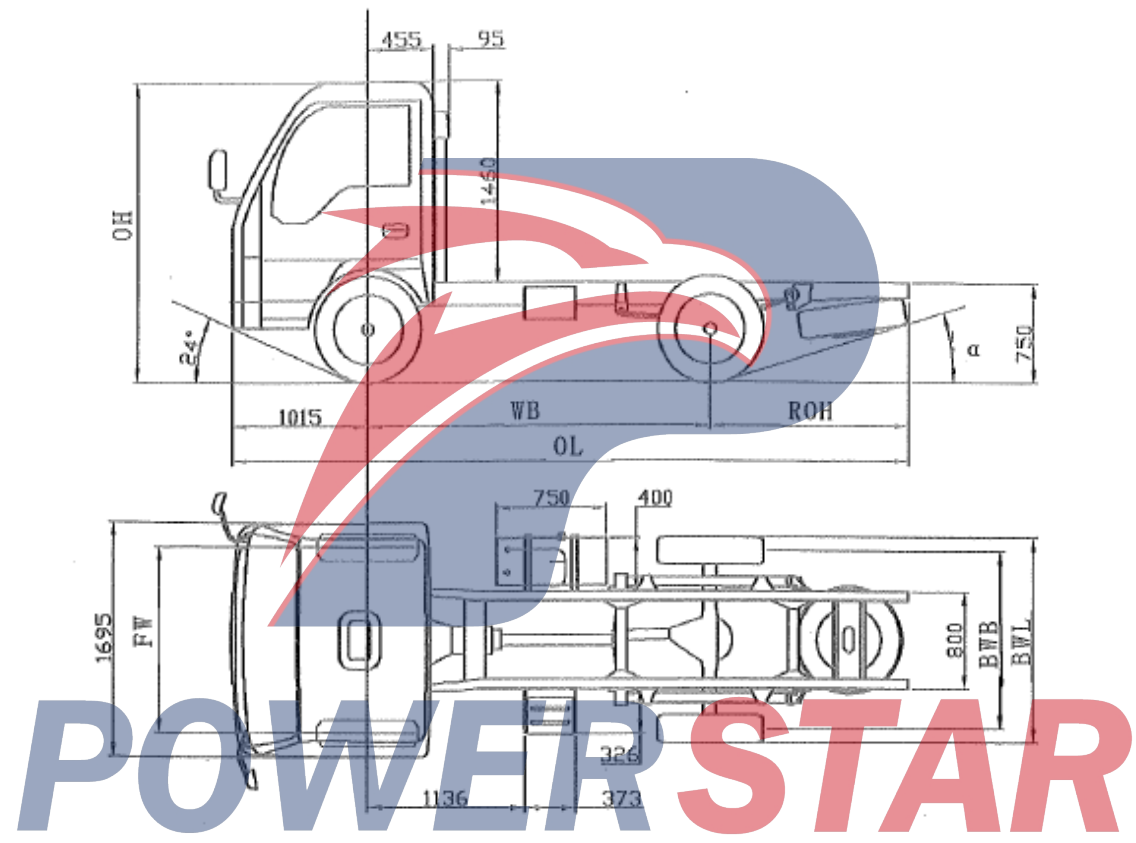
Project	Unit	Chassis model,																
		QL1040 3EARY	QL1040 3EWRV	QL1040 3 EWRIY	QL1040 3FARY	QL1040 3FWRY	QL 1050 3PWRY	QL1040 3HARY	QL1060 3HARY	QL 1040 3HARY	QL1040 3HWRY	QL1050 3HWRV	QL1070 3HARY	QL1070 3HWRY	QL1070 3KARY	QL1070 3KWRY	QL1070 3KAR1Y	
Emission Level		GB17691-2005(GB IV), GB3847-2005																
Number of passengers allowed in the cab	Person	2	2+3		2	2+3		2			2+3		2	2+3	2	2+3	2	
Kerb mass		1680	1820	1820	1010	1960	1960	1850	1850	1050	2050	2050	2000	2150	2050	2200	2110	
Chassis axle load	Front axle	kg	1070	1200	1280	1090	1270	1270	1200	1200	1200	1350	1350	1260	1410	1310	1430	1325
	Rear axle	kg	610	540	540	720	690	690	650	650	650	700	700	740	740	740	770	765
Allowable maximum total mass	kg	4200	4100	3620	4499	4290	4645	4475	5300	5000	4480	5300	7300	6725	7300	6725	7300	
maximum axle load	Front axle	kg	1890	1690	1560	1640	1490	1500	1800	1920	2100	1570	1970	2580	2005	2580	2005	2580
	Rear axle	kg	2310	2410	2060	2859	2800	3145	2675	3380	3700	2910	3330	4720	4720	4720	4720	4720
Vehicle length	mm(OL)	4605			5230						5900				6645			
Vehicle width (at cab)	mm								1695									
1. Vehicle width( at rear shaft)	mm(BWL)	1610			1860					1880			2090					
Vehicle height	rmm(OH)	2105			2180					2220								
Wheel base	mm(WB)	2490			2765					3360			3815					
Front track	mm(FW)	1385							1504									
Rear track	mm(BWB)	1395			1425												1525	
Front suspension	mm	1015																
Rear Overhang	mm(ROH)	1100			1450	1525					1815							
Approach angle	°	24°																
Departure angle	°(a)	20°			16°										14°			
Height of frame from ground (at rear axle)	mm	730																

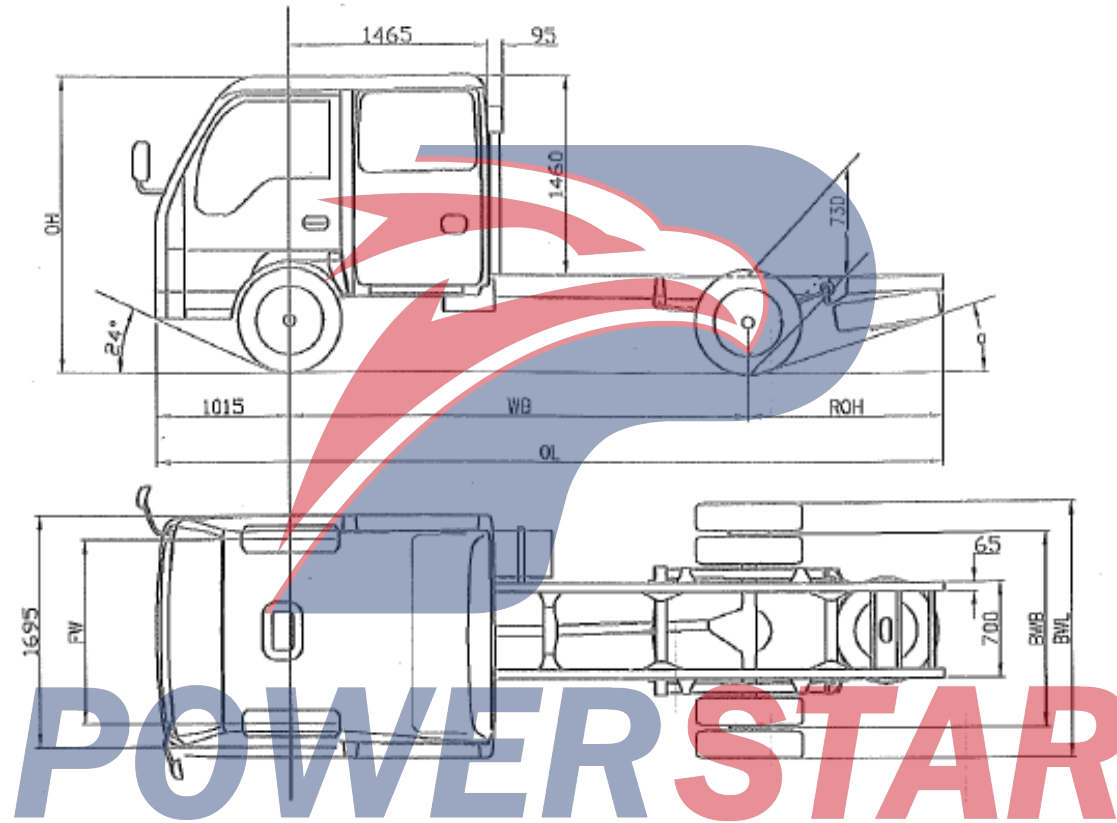


**Table of Chassis Parameters of Series N**

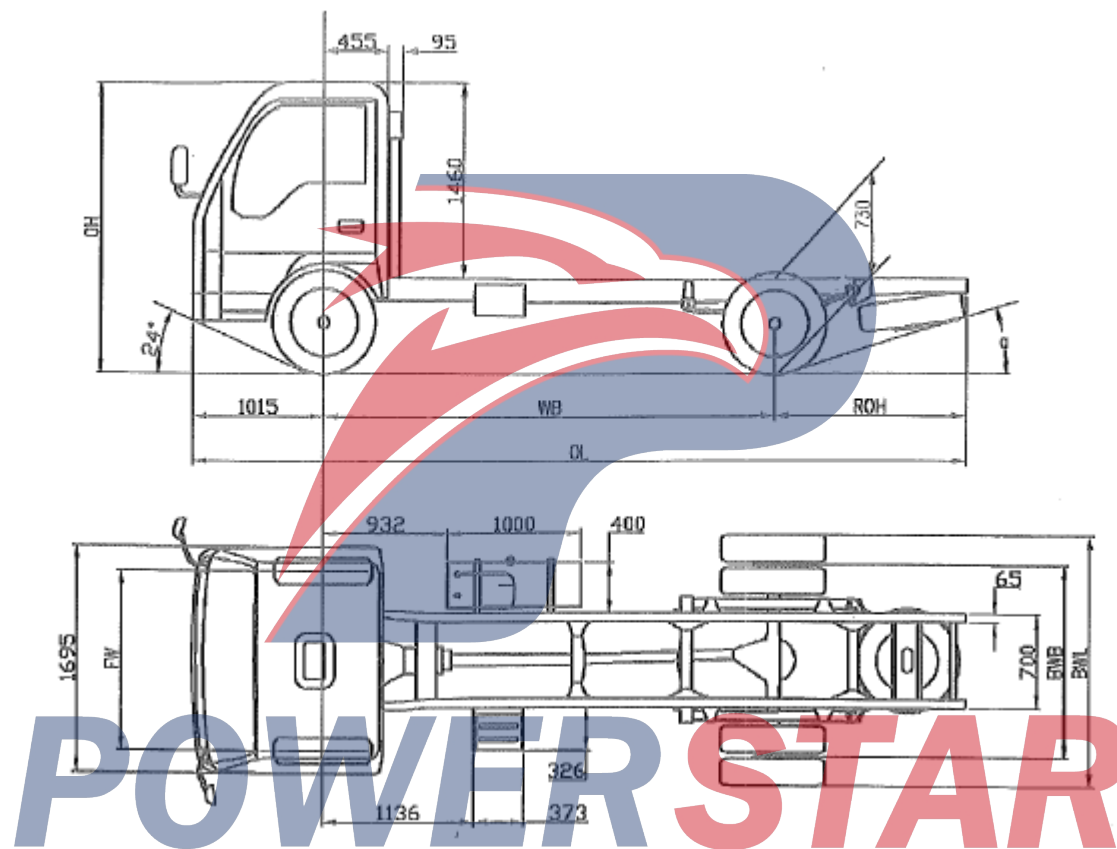
Project	Unit	Chassis model								
		QLI0403EWR2Y	QL10413EARY	QLI0413FARY	QL10503HARIY	QLI0403HHRY	QL 10413HARY	QL 10423HARY	OL104 13HWRY	
Emission Level		GB17691-2005 (GB IV) . GB3847-2005								
Number of passengers allowed in the cab	Person	2 + 3						2	2 + 3	
Kerb mass	kg	1820	1 680	1810	1050	1 900	1850	1 700	2050	
Chassis axle load	Front axle	kg	1 280	1070	1090	1200	1250	1200	9 10	1 3.50
	Rear axle	kg	540	610	720	650	650	650	790	700
Allowable maximum total mass	kg	4100	3510	3780	5300	4475	3790	3650	4215	
maximum axle load	Front axle	kg	1 690	1580	1380	1920	1800	1525	1 380	1480
	Rear axle	kg	24 10	1 930	2400	3380	2675	2265	2270	2735
Vehicle length	mm (OL)	4605		5230	5900					
Vehicle width(at cab)	mm	1695								
Vehicle width(at rear axle)	mm (BWL)	1610			1860					
Vehicle height	mm (OH)	2105			2180					
Wheel base	mm (WB)	2490	2765		3360					
Front track	mm (FW)					1385				
Rear track	mm (BWB)	1395		1425						
Front suspension	mm	1015								
Rear Overhang	mm (ROH)	1100		1450	1525					
Approach angle	°	24°								
Departure angle	° (a)	20°			16°					
Height of frame from ground (at rear axle)	mm	730								













### Tools with vehicle

Serial number	Tool name	Specification	Quantity	Vehicle model		
				QL*E*	QL*F*	QL*H*
1	Workbasket	-	1	☆	☆	☆
2	Double-ended wrench	17X22	1	☆	☆	☆
3	Double-ended wrench	12x14	1	☆	☆	☆
4	Double-ended wrench	8X10	1	☆	☆	☆
5	Jaws	150	1	☆	☆	☆
6	Adjustable wrench	200x24	1	☆	☆	☆
7	"+"-"Combined driver	—	1	☆		
8	Wheel nut wrench	23	1		☆	☆
		41x19	1		☆	☆
9	Valve wrench	-	1		☆	☆
10	Oil pressure Jack	QYSH4	1	☆		
		QYH4D	1		☆	☆
11	Jack rocker arm	—	1	☆	☆	☆
12	Wheel wrench	—	1		☆	☆
13	Backup lifter rocker	-	1	☆	☆	☆

**POWER STAR**